

Article

Unveiling the influence of ESG disclosures on corporate profitability: Insights from Thailand's publicly listed companies

Kanitsorn Terdpaopong¹, Gregory Wegmann², Tanpat Kraiwanit^{3,*}, Pongsakorn Limna³, Aishath Rafiyya³¹ Faculty of Accountancy, Rangsit University, Pathum Thani 12000, Thailand² School of Management, University of Burgundy, Dijon 21078, France³ Faculty of Economics, Rangsit University, Pathum Thani 12000, Thailand* **Corresponding author:** Tanpat Kraiwanit, tanpat.k@rsu.ac.th

CITATION

Terdpaopong K, Wegmann G, Kraiwanit T, et al. (2024). Unveiling the influence of ESG disclosures on corporate profitability: Insights from Thailand's publicly listed companies. *Journal of Infrastructure, Policy and Development*. 8(7): 4787. <https://doi.org/10.24294/jipd.v8i7.4787>

ARTICLE INFO

Received: 21 February 2024

Accepted: 27 March 2024

Available online: 31 July 2024

COPYRIGHT



Copyright © 2024 by author(s).

Journal of Infrastructure, Policy and Development is published by EnPress Publisher, LLC. This work is licensed under the Creative Commons Attribution (CC BY) license.

<https://creativecommons.org/licenses/by/4.0/>

Abstract: This study investigates the influence of Environmental, Social, and Governance Disclosures (ESGD) on the profitability of firms, using a sample of 385 publicly listed companies on the Thai Stock Exchange. Data from 2018 to 2022 is sourced from the Bloomberg database, focusing on ESGD scores as indicators of companies' ESG commitments. The study utilizes a structural equation model to examine the relationships between independent variables; ESGD, Earnings Per Share (EPS), Debt to Assets ratio (DA), Return on Investment Capital (ROIC), Total Assets (TA), and dependent variables Tobin's Q (TBQ) and Return on Assets (ROA). The analysis reveals a positive relationship between ESGD and TBQ, but not with ROA. Further exploration is conducted to determine if different ESGD levels (high, medium, low) yield consistent effects on TBQ. The findings indicate discrepancies: high and medium ESGD levels are associated with a negative impact on TBQ when EPS increased, whereas low ESGD levels correlate with an increase in TBQ with rising EPS. This nuanced approach challenges the conventional uniform treatment of ESGD in previous research and provides a deeper understanding of how varying commitments to ESG practices affect a firm's market valuation and profitability. These insights are crucial for firm management, highlighting the importance of ESGD in relation to other financial variables and their effects on market value. This study offers a new perspective on ESGD's impact, emphasizing the need for differentiated strategies based on ESG commitment levels.

Keywords: environmental, social, and governance disclosures (ESGD); profitability of firms; structural equation model; Tobin's Q (TBQ); return on assets (ROA)

1. Introduction

Environmental, social, and governance disclosures (ESGD) have become increasingly important in evaluating a company's performance and sustainability (Alsayegh et al. 2020; Papoutsis and Sodhi, 2020). The importance of ESGD resides in their capacity to offer stakeholders a comprehensive perspective (Camilleri, 2015) on a company's actions and their repercussions on the environment, society, and corporate governance. The level of openness not only impacts the decisions made by investors but also molds the reputation and market positioning of the organization. The priority of ESGD considerations by investors, potential investors, and business leaders is of utmost importance for various reasons (Hill, 2020). ESG standards provide a perspective for investors and potential investors to assess the long-term sustainability and ethical integrity of a company. This viewpoint is becoming more and more significant in a worldwide market where sustainable actions are not just favored but also anticipated. Investing in companies that prioritize ESG policies is commonly

regarded as less risky. These organizations demonstrate greater resilience to environmental and social disruptions, legislative modifications, and changes in customer preferences. Furthermore, there is an increasing acknowledgment that organizations with strong ESG frameworks are more likely to deliver enduring, profitable outcomes, thereby making them appealing investment prospects.

Corporate executives and management must prioritize ESG aspects in order to sustain a competitive advantage (Dkhili, 2023). Companies that excel in ESG policies frequently experience enhanced ability to attract and retain highly skilled individuals, as employees are increasingly inclined to seek companies whose principles fit with their own (Wu and Tham, 2023). This alignment can also encompass customer loyalty, as the consumer base becomes increasingly aware of the ethical consequences of their purchases. Furthermore, placing significant emphasis on ESG factors can stimulate innovation (Zhang and Jin, 2022), since it frequently necessitates organizations to reassess and enhance their operational procedures, product concepts, and supply networks to adhere to more stringent environmental and social criteria. This invention has the potential to result in reduced expenses, provide fresh market prospects, and strengthen brand value. In addition, the regulatory environment is changing rapidly, as countries and international organizations are enforcing increasingly stringent norms and reporting obligations around sustainability and corporate responsibility. Companies that have previously incorporated ESG factors into their operations are in a more advantageous position to adhere to these rules, hence mitigating the risk of incurring penalties and sanctions (Barko et al., 2022). Adopting this proactive strategy might also result in a more positive perception from regulators, thereby exerting influence on future policy deliberations and industry norms.

Emphasizing ESG concerns is a crucial and necessary strategy for both investors and corporate executives (Hoang, 2018; Sciarelli et al., 2021). ESGD can immediately affect a company's performance by directly influencing investor behavior (Carnini Pulino et al., 2022; Chen and Xie, 2022). Investors are increasingly drawn to organizations that have a strong dedication to ecological and ethical activities. The change in investor preferences might result in a rise in capital inflow for companies that demonstrate excellence in ESG activities, potentially improving their market value and financial performance (Matos, 2020). In addition, implementing efficient ESGD can help minimize risks by proactively addressing environmental and social concerns, hence decreasing the probability of regulatory fines or harm to one's reputation.

ESG disclosures have a significant impact on a company's long-term strategic orientation and sustainability (Chevrollier et al., 2020; Zumente and Bistrova, 2021). Companies that successfully incorporate ESG practices into their fundamental strategies are generally more robust and flexible in response to shifting market and environmental circumstances. Adopting a long-term outlook is crucial for achieving sustainable growth and profitability, as it promotes innovation, employee involvement, client retention, and operational effectiveness. Moreover, robust ESG practices can result in enhanced risk management, as organizations that possess knowledge about their environmental and social effects are more inclined to foresee and adjust to regulatory modifications and societal transformations (Schaltegger and Wagner, 2011; Schot and Steinmueller, 2018).

ESGD are of utmost significance for management, investors, and governments. These disclosures provide management with a valuable tool for internal evaluation and strategic planning (Passeti et al., 2018), enabling them to pinpoint areas that require enhancement in terms of sustainability and social responsibility. Engaging in this self-reflection can result in improved operational effectiveness, better risk control, and eventually, a more advantageous market position. Investors, however, primarily depend on ESGD to make well-informed judgments (Vizcarra, 2020). These observations allow them to evaluate the long-term sustainability and moral position of their investments, connecting monetary performance with social and environmental influence. ESGD are crucial for policymakers since they enable the monitoring and regulation of corporate activity (Arvidsson and Dumay, 2022), ensuring that corporations comply with sustainability requirements and make good contributions to societal objectives. Effective ESGD establish a transparent framework in which business actions are in line with wider environmental and social goals, hence influencing responsible investment and policy development (Giannarakis et al., 2014; Sciarelli et al., 2021; Singhania and Saini, 2023).

The empirical evidence on the influence of ESGD on financial indicators, such as Tobin's Q (TBQ), return on assets (ROA), return on equity (ROE) and even stock prices of those firms that disclose ESG, is conspicuously deficient or lack of same conclusions. This lack is emphasized by the general discussions surrounding the impact of ESG on financial performance, which lack specific metrics (Carnini Pulino et al., 2022; Matos, 2020). Further exploration is needed to understand the nuanced effects of different levels of ESGD on profitability, as the current literature lacks detailed analysis (Alsayegh et al., 2020; Papoutsi and Sodhi, 2020). Moreover, the impact of ESGD on financial performance across various industries and regions remains an area that has not been thoroughly explored (Dkhili, 2023; Hill, 2020). The time-related effects (Chevrollier et al., 2020; Zumente and Bistrova, 2021) and the mechanisms (Sciarelli et al., 2021; Wu and Tham, 2023) through which ESGD affect financial performance have not been thoroughly addressed in existing studies. There is an ongoing controversy surrounding the quantification of the impact of ESGD on financial performance. Sector-specific and geographical differences may significantly impact financial performance across sectors and regions (Dkhili, 2023; Hill, 2020). Understanding investment timeframes requires distinguishing between the short-term and long-term financial impacts of ESGD, which is not clearly addressed in existing studies (Chevrollier et al., 2020; Zumente and Bistrova, 2021).

To comprehend the influence of ESG practices, it is imperative to quantify the relationship between ESGD and financial performance indicators. Although this relationship has been broadly suggested in the existing literature, it has not been specifically concluded in the same direction (Carnini Pulino et al., 2022; Chen and Xie, 2022). Furthermore, it is critical to explore how different degrees of ESGD influence firm profitability, as current research lacks detailed insights into this aspect (Alsayegh et al., 2020; Papoutsi and Sodhi, 2020). It is not solely the financial impact that should be focused on. Investigating non-financial indicators such as specific operational, reputational, and strategic mechanisms through which ESGD affect financial performance is crucial. The current literature often acknowledges the impact of ESG without providing detailed insights into the underlying pathways (Sciarelli et

al., 2021; Wu and Tham, 2023). These gaps and issues give rise to a comprehensive area of investigation that aligns with our research objectives, which seek to comprehend and measure the impact of ESGD on financial performance.

The aim of this study is to examine the impact of ESGD on the financial performance of companies. The study aims to ascertain the extent to which ESGD have a substantial influence on a company's performance, as evaluated by two important financial indicators: Tobin's Q (TBQ) and return on assets (ROA). Additionally, the study seeks to examine whether the impact on firm profitability varies across different degrees of ESG disclosures. This objective aims to explore the correlation between ESGD and firm's profitability, specifically examining if different levels of ESGD (e.g., low, medium, high) have varying effects on a firm's profitability. The objectives are not only to establish a fundamental comprehension of the correlation between ESGD and firm performance, but also to delve into the intricacies and nuances within this correlation, providing a more comprehensive perspective on how ESG practices impact financial outcomes.

2. Literature review

In the context of the increasing importance attributed to ESGD, multiple theoretical frameworks offer a comprehensive insight into their effects on company performance. Stakeholder theory (Freeman, 2010) emphasizes the importance of addressing the needs and concerns of diverse stakeholders, including investors, employees, and the community (Donaldson and Preston, 1995). It suggests that firms with strong ESG practices may benefit from improved relationships and performance outcomes (Al-Maliki et al., 2023; Arianpoor et al., 2023; Bagh et al., 2024; Bagh, et al., 2023; Salehi and Alkhyoon, 2022; Salehi et al., 2018). Moreover, agency theory (Means, 2017; Meckling and Jensen, 1976) emphasizes how ESGD can help mitigate conflicts between principals and agents (Peng and Isa, 2020) by aligning managers' behaviors with shareholders' interests, fostering transparency, and reducing information asymmetry (Al-Maliki et al., 2023; Bagh et al., 2024; Bagh, et al., 2023; Salehi and Alkhyoon, 2022). Additionally, legitimacy theory (Dowling and Pfeffer, 1975) highlights the importance of ESG practices in ensuring that a company's activities conform to societal norms and expectations (Magness, 2006), thus maintaining its legitimacy to operate and building trust among stakeholders (Al-Khoury and Basith, 2022; Arianpoor et al., 2023; Hummel and Schlick, 2016; Nuhu and Alam, 2024; Wasiuzzaman et al., 2022). At the same time, signaling theory proposes that companies can enhance their reputation and attract supportive investors and customers by signaling their commitment to ESG principles (Al-Khoury and Basith, 2022; Salehi et al., 2018; Wasiuzzaman et al., 2022). Taken together, these theories underscore the diverse ways in which ESGD can impact company performance, not only through direct financial consequences but also by influencing perceptions, relationships, and institutional alignments. Nevertheless, despite the theoretical foundations, there persist enduring empirical gaps in assessing the direct influence of ESGD on financial performance metrics. Furthermore, the nuanced implementation of these theories across varying levels of ESG disclosure and in different industries and geographical contexts is still largely unexplored. This absence

of detailed empirical proof and analysis highlights a crucial research void. By addressing these gaps, it is possible to clarify the specific mechanisms by which ESGD affect firm performance and how these theoretical frameworks materialize in actual corporate results.

The correlation between ESG factors and corporate performance has been extensively studied and verified in many research. Several papers (Nuhu and Alam, 2024; Shafeeq Nimr Al-Maliki et al., 2023) introduced the board characteristics as factors influencing the ESGD and firm's performance. The authors of those research found that some type of board characteristics did impact how the firm would disclose the ESGD and such in turn impact the firm's performance at the later stage. The studies conducted by Zhang et al. (2023) found that there is a negative correlation between ESGD and earning management of the firms of their study (European and Asian contexts) and media attention is the factor that enhance the deterrent effect of ESGD on earnings. The focus on Asian countries is also emphasized more especially in Indonesia, Malaysia, Philippines, Thailand, and Vietnam (Makhdalena et al., 2023). The study found that developing countries have a positive effect between ESGD and company performance (measured by TBQ, EPS and ROA). In the long term, ESG would build effective governance and increase shareholder value for the companies. Wicaksono (2023) indicate that the disclosure of ESG information has a substantial positive impact on the overall performance of companies. Their conclusions are derived from data obtained from the Thomson Reuters database and company websites, which were subjected to panel data analysis and regression tests for analysis. However, these studies do not investigate the specific impacts of ESGD in European and Asian contexts.

Şeker and Şengür (2021) discovered that there is a connection between organizations' ESG performance, specifically in the areas of environmental and governance, and an enhancement in financial reporting quality. The study employs panel regression techniques and includes data from 16,072 observations of firms across multiple years in 35 different countries, provides insight into the wider influence of ESG factors on the level of financial openness and responsibility. It was found a strong and meaningful correlation between the various financial reporting quality proxies in their study. This is also aligned with the finding from Tehran Stock Exchange (TSE), Iran's largest stock exchange, where the investment in CSR initiatives is significantly and positively associated with firm financial performance as measured by changes in return on assets, and changes in operating cash flows to total assets (Salehi et al., 2018).

There are variations in ESGD and corporate performance between European and Asian countries. Multiple studies have investigated the correlation between ESG disclosure and the financial performance of companies. A study conducted by Khandelwal et al. (2023) discovered a negative ESG disclosure premium, suggesting that companies that have higher levels of disclosure experience worse returns in comparison to those with lower levels of disclosure. A recent study examined panel data from ASEAN and discovered that the disclosure of nonfinancial information can pose a risk to the generation of firm value, resulting in a decrease in market value (Hua, 2022). Nevertheless, a research investigation centered on European corporations unveiled a favorable and noteworthy correlation between ESG ratings and company

success, as evidenced by levered free cash flow, return on equity (ROE), current ratio, and quick ratio (Palupi, 2023). These data indicate that the correlation between ESG disclosure and company performance may change among various areas. Additional investigation is required to comprehend the precise reasons that influence this correlation in European and Asian nations. Kenny et al. (2022) who conducted a study on ASEAN countries, discovered that the disclosure of ESG factors has a negligible effect on the financial performance of companies. Their investigation, utilizing a fixed effect model and robust standard errors, also observes that integrated reporting does not impact the correlation between ESG disclosure and business performance. The lack of a moderating effect questions the premise that ESG disclosures always have a positive or negative impact on corporate performance.

Nevertheless, Submitter et al. (2020) propose a more intricate perspective. The study found that ESG disclosures have a favorable effect on business value in Thailand, whereas governance disclosures have a negative effect. This is demonstrated by employing content analysis and multiple regression techniques, with a specific emphasis on the Thai market and its primary market data (Submitter et al., 2020). However, the study conducted by Treepongkaruna and Suttipun (2024), even though conducted in the same geography, found statistically significant and positive impact of ESG reporting on corporate profitability in Thailand. Thanjunpong et al. (2019) emphasize the impact of Sustainable Development Reports (SDR) on the performance of companies, particularly in the Thai setting. Their research demonstrates a notable and favorable correlation between SDR and the overall success of organizations that have strong and effective corporate governance. This evaluation is conducted using the questionnaires provided by the Global Reporting Initiative. Regarding integrated reporting, Van Brecht et al. (2018) also highlight the favorable correlation between ESG disclosure and the value of companies in the Thai market. By employing Ohlson's valuation model and Bloomberg's ESG disclosure score, the authors show that the Thai market positively reacts to extensive ESGD.

While numerous studies have highlighted the favorable impact of ESG disclosures, several studies have also identified a negative association. Khandelwal et al. (2023) discovered a negative correlation between ESG disclosure and financial returns, indicating that companies that disclose more information about their environmental, social, and governance practices tend to have poorer profitability compared to those with lower levels of disclosure. This statement questions the widely accepted notion that more transparency through ESG disclosure always results in improved financial performance.

Zhang et al. (2023) contribute to this ongoing discussion by emphasizing a negative association between ESG disclosure and earnings management. Their study examines the impact of media attention on A-share listed businesses in Shanghai and Shenzhen between 2009 and 2021, with a particular focus on the role of media attention as a moderating variable. This implies that the correlation between ESG disclosure and business performance management is intricate and subject to external influences such as public attention. Mendiratta et al. (2023) provide additional evidence of this intricacy within the Indian context, demonstrating that ESG debates have a detrimental impact on business performance. Curiously, they observe that the effectiveness of the government has a detrimental effect on the response to these ESG

concerns. This discovery suggests that the legislative and political framework has a crucial impact on how ESG influences company results. Palupi (2023) emphasizes the importance of emerging nations and highlights environmental performance, which is typically a crucial aspect of ESG. The study provides significant ecological consequences and finds a negative impact on a company's financial situation. Based on ASEAN panel data, this paper contends that the disclosure of nonfinancial information, which is commonly included in ESG reporting, has the potential to undermine the generation of corporate value (Palupi, 2023). In a similar vein, Kurniawan and Rokhim (2023) observe that the relationship is not considerably influenced by ownership concentration and equity balance, but it is influenced by institutional ownership. This underscores the significance of various ownership structures on the correlation between ESG performance and financial outcomes. In summary, these researches indicate that ESGD and performance can have both positive and negative effects on business performance, depending on the specific circumstances. Media attention, government performance, ecological costs, ownership structure, and the specific geographical context are important factors that greatly influence these outcomes. This research emphasizes the importance of having a detailed understanding of the influence of ESG. It challenges the idea that ESG variables always have a positive effect on a company's success.

Expanding upon the previous conversation about the adverse influence of ESGD on company performance, it is important to mention that certain studies have discovered no substantial correlation between these aspects. This feature contributes to the intricacy of comprehending the relevance of ESG in corporate situations. The sentiment expressed in Thailand is echoed by the survey done by Phoprachak and Buntornwon (2020). Their study examined 402 companies listed on the Stock Exchange of Thailand and employed the Multiple Indicator and Multiple Cases (MIMIC) model to evaluate the correlation between environmental disclosure and financial success. Once again, the results showed no significant link, indicating that the influence of environmental disclosures, which are an essential part of ESG practices, on financial performance is not easily understood.

When examining the negative effects of ESG alongside this research, it becomes evident that ESG has a multifaceted and diverse impact on business performance. The authors emphasize the significance of considering context and specificity when assessing the impact of ESGD. They propose that the consequences of these practices can vary from detrimental to inconsequential, contingent upon factors such as regional attributes, industry, and the specific dimensions of ESG under examination. The variety of results found in these studies contradicts the idea that ESG can be universally applied and highlights the importance of a more sophisticated and discerning approach when evaluating its influence on company performance.

Integrating the results from various research on the impact of ESG factors on company performance, in accordance with the principles of stakeholder theory (Huang, 2022; Tarmuji et al., 2016), provides a thorough comprehension of the interplay between these components in the business realm. The diverse effects of ESG practices, which can range from detrimental to inconsequential, underscore the significance of context, industry, and geographical attributes in influencing their efficacy. The presence of this variability highlights that the impact of ESG is not consistent but

depends on several conditions. This challenges the idea of a one-size-fits-all strategy to implementing ESG. A comprehensive and discerning evaluation of ESG's function is necessary to fully comprehend its genuine influence on business performance. Stakeholder theory is useful for analyzing and incorporating ESG practices in this situation (Harrison and Wicks, 2013; Laplume et al., 2008). Stakeholder theory connects harmoniously with the multifarious character of ESG by highlighting the importance of addressing the requirements of all stakeholders, including as consumers, employees, suppliers, communities, and the environment. This philosophy promotes a business strategy that goes beyond prioritizing shareholder profits to include wider societal and environmental concerns. By integrating ESG practices with stakeholder theory, we may effectively negotiate the intricacies emphasized in the diverse ESG research findings. This comprehensive strategy not only helps reduce risks and improve the reputation of the brand, but also reinforces long-term relationships with stakeholders, which are essential for maintaining commercial success over time.

Supported by relevant research findings, the following hypotheses are offered based on a comprehensive literature evaluation and the theoretical framework of this study:

- Hypothesis 1: ESGD has a positive impact on a firms' performance.

This hypothesis suggests that there is a direct correlation between the level of ESGD and the performance of a company. Research substantiates this claim by demonstrating that companies that engage in thorough ESGD frequently witness an increase in investor confidence and market value, which can potentially result in improved financial indicators such as greater Tobin's Q and Return on Assets (ROA). Research has demonstrated that implementing transparent ESG reporting is linked to a decrease in investment risks and an increase in investor interest. These factors can have a favorable impact on a company's overall performance.

- Hypothesis 2: Varied levels of ESGD exert distinct influences on firms' performance.

The second hypothesis posits that the effect on company performance is contingent upon the extent of ESGD. This is based on research that shows that not all ESGD have the same level of impact. Enhanced and comprehensive ESG reporting, showcasing a stronger dedication to sustainability and governance, is frequently associated with more significant beneficial effects on company performance. In contrast, limited or surface-level ESGD may not result in the same advantageous outcomes. This theory is consistent with research indicating that the extent and excellence of ESG practices, as seen in disclosures, are crucial determinants of their influence on business performance.

These hypotheses seek to investigate the intricate correlation between ESGD and business performance, considering both the existence and the amount of such disclosures. This approach provides a thorough comprehension of how ESG practices impact corporate outcomes.

3. Materials and methods

The study employed Structural Equation Modeling (SEM) as a tool to assess the influence of several independent variables on business profitability, as measured by Tobin's Q (TBQ) and Return on Assets (ROA). SEM is a powerful statistical method that enables the examination of many connections between observed and underlying variables (Lowry and Gaskin, 2014). This makes it well-suited for investigating intricate models, like the one suggested in this research. The investigation utilized data obtained from the Bloomberg dataset, which offered a comprehensive compilation of information pertaining to publicly traded corporations. According to data from Bloomberg Intelligence, it is expected that worldwide ESG assets would surpass \$53 trillion by 2025, accounting for almost one-third of the estimated total assets under management of \$140.5 trillion. In order to be included in Bloomberg, the data submitted by the company must account for a minimum of 80% of its operations and 80% of its workforce. This is done to ensure that a disclosure score accurately reflects the activity of the organization (Bloomberg Professional Services, 2022).

The sample consisted of 385 companies that were listed on the Stock Exchange of Thailand, which ensured that the study was focused on an economic and regulatory environment. The selection of these companies was based on the comprehensiveness of their data, guaranteeing the dependability and precision of the study. The selection of the Stock Exchange of Thailand as the location for this study provides a valuable viewpoint on the interplay between ESGD and firm performance in a developing market. This market may display distinct features compared to more established markets. This method not only enhances the current understanding of the relationship between ESG and business performance, but also offers valuable and applicable insights for organizations operating in similar market environments. To assess the sufficiency and efficiency of the SEM utilized in this work, various essential measures of goodness-of-fit were utilized. These metrics are crucial for assessing the degree of fit between the proposed model and the observed data. The metrics utilized consist of the Chi-Square to Degree of Freedom ratio, p-value, Goodness of Fit Index (GFI), Comparative Fit Index (CFI), and Root Mean Square Error of Approximation (RMSEA) (Marcoulides and Yuan, 2017). The p-value metric evaluates the likelihood of the observed data occurring on the assumption that the null hypothesis is true. In structural equation modeling (SEM), a high p-value generally signifies that the estimated covariance matrix of the model does not significantly deviate from the observed covariance matrix, indicating a satisfactory fit. The Chi-Square to Degree of Freedom Ratio (Chi/DF) is employed to standardize the chi-square value by dividing it by the degrees of freedom in the model. A lower ratio typically signifies a more optimal match. Acceptable numbers typically vary based on the model's complexity and the topic of research, but ratios as low as 2 or 3 are generally seen as indicative of a satisfactory match. The Goodness of Fit Index (GFI) quantifies the extent to which the model explains the observed data's variation. A GFI value close to 1 suggests a strong fit, indicating that the model effectively accounts for the observed variance and covariance in the data. The Comparative Fit Index (CFI) assesses the degree of fit between the target model and an independent model, typically a null model that assumes no correlations between variables. Values approaching 1 are preferable, as

they indicate that the proposed model offers a significantly superior fit to the data compared to the null model. The last statistic, Root Mean Square Error of Approximation (RMSEA), assesses how well the model matches the covariance matrix of the population. RMSEA values below 0.05 suggest a good fit, but values up to 0.08 are regarded as acceptable, indicating a respectable level of approximation error (Marcoulides and Yuan, 2017; West et al., 2023).

Each of these indicators provides a distinct viewpoint on the model’s appropriateness, and collectively, they offer a thorough evaluation of how accurately the SEM represents the underlying data. When doing SEM analysis, it is essential to consider all these indices together. Depending on a single metric can result in deceptive conclusions on the suitability of the model. **Table 1** shows variable list and descriptive statistics.

Table 1. Variable list and descriptive statistics.

Ratio	Description	Minimum	Maximum	Mean	Std. Deviation
TBQ	Ratio between a physical asset’s market value and its replacement value. If Tobin’s q is greater than 1.0, the market value is greater than the value of the company’s recorded assets.	0.712	11.775	1.778	1.409
ROA	Return on Assets (ROA) measures the profitability of a business in relation to its total assets. ROA indicates how well a company is performing by comparing the profit (net income).	-60.836	48.234	5.279	7.484
ESGD	ESG disclosure is a form of public reporting by an organization’s management team about its performance across a variety of Environmental, Social, and Governance (ESG) issues.	6.861	81.622	51.127	14.923
EPS	Earnings per share (EPS) is a company’s net profit divided by the number of common shares it has outstanding.	-64.680	40.030	2.971	6.481
DA	Debt to asset ratio (DA) is used to understand the degree to which a company’s operations are funded by debt and shows capital structure.	0.000	111.711	29.791	19.453
ROIC	Return on invested capital (ROIC) assesses a company’s efficiency in allocating capital to profitable investments, calculated by dividing net operating profit after tax (NOPAT) by invested capital. After calculation, natural logarithm is taken.	-99.959	84.095	6.937	10.418
LnTA	Firm size (SIZE), measured by the natural logarithm of total assets, controls for effects of scale economies and market power associated with a firm’s size.	6.799	15.302	11.529	1.730

n: 385. ESGD A rank with the scores over 60.00, n: 112; B rank with the score ranges 41–60, n: 175; C rank with the score lower 40, n: 98. Source: Compiled by authors.

The TBQ variable reveal significant variation across the firm samples, with an average of 1.778. This benchmark often suggests that a firm’s market value is above its replacement cost (minimum: 0.712, maximum: 11.775, and standard deviation: 1.409). The ROA values exhibit significant variability, with the smallest and greatest values representing extremely negative and positive values, respectively. The positive mean value indicates that, on average, companies produce a favorable return on their assets.

4. Results and discussions

The goal of this study is to analyze the impact of independent variables on profitability, and the findings are presented accordingly. The study primarily examines the relationship between ESGD and other significant variables that may impact TBQ and ROA. Structural equation modeling is employed to determine the optimal fit of

the model to the financial indicators of Thai listed companies. The diagram below illustrates the optimal model.

Figure 1 displays five independent variables, namely ESGD, EPS, DA, ROIC, and LnTA, which are analyzed to determine their impact on the dependent variables TBQ and ROA. Structural equation modeling was developed and determined a statistically significant positive influence of ESGD and ROIC on TBQ. Both of these values indicate the regression weight, with standardized coefficients of 0.16 and 0.22, respectively. Only the Return on Invested Capital (ROIC) has a positive influence on the Return on Assets (ROA), with a standardized regression weight of 0.65. This implies that ESGD provides an additional benefit to TBQ, which is considered a market value from an investor’s standpoint. ESGD has no discernible impact on ROA. Other variables, such as EPS, DA, and LnTA, were found to have a detrimental influence on TBQ. The TBQ is not increased by the greater value among EPS, DA, and size evaluated by LnTA. Their regression weights, standardized, are -0.18 , -0.17 , and -0.33 , respectively. Both DA and LnTA exhibit a similar pattern of negative impact on ROA, with regression weights of -0.1 and -0.24 , respectively. ROIC is the only factor that has a positive impact on ROA, with a regression weight of 0.65. The analysis of each variable’s path is displayed in **Table 2**. Each path demonstrates the unstandardized, standardized, standard error, critical ratio, and p-value. The primary objective of this study is to analyze the influence of ESGD on profitability, namely TBQ and ROA. However, only TBQ was determined to have a statistically significant impact at a confidence level of 95%. Refer to **Table 2**.

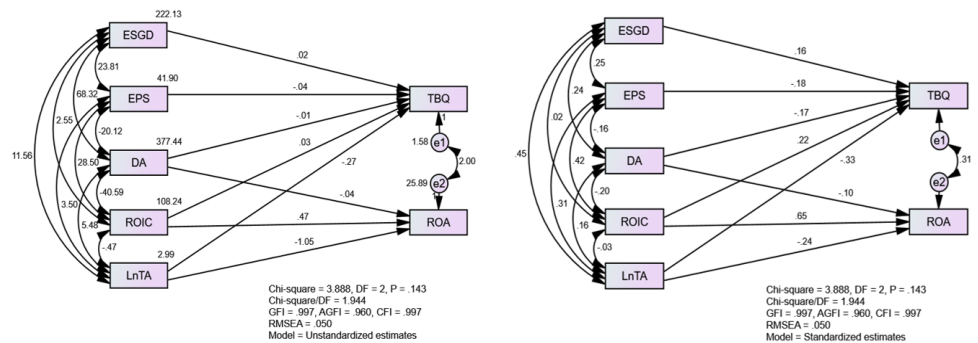

Figure 1. Structural equation modeling of Thai listed companies.

Source: Compiled by authors.

Table 2. Path analysis—regression weights.

	Unstandardized	Standardized	S.E.	C.R.	P
TBQ → ESGD	0.015	0.160	0.005	3.203	0.001
TBQ → EPS	-0.040	-0.183	0.011	-3.482	***
TBQ → DA	-0.013	-0.173	0.004	-3.554	***
ROA → DA	-0.040	-0.104	0.014	-2.894	0.004
TBQ → ROIC	0.030	0.219	0.007	4.291	***
ROA → ROIC	0.467	0.650	0.025	18.343	***
TBQ → LnTA	-0.268	-0.329	0.043	-6.232	***
ROA → LnTA	-1.050	-0.243	0.152	-6.896	***

Source: Compiled by authors.

The structural equation modeling yields a chi-square value of 3.888, with 2 degrees of freedom and a *p*-value of 0.143. These findings suggest that the data and the model have a strong match, as indicated by a chi-square to degree of freedom ratio of 1.944 (below 3.0 is considered favorable). The goodness of fit of the model, as measured by GFI, AGFI, and CFI, is above 0.900 and close to 1.0. Furthermore, the RMSEA value of 0.050, which is close to 0.00, is also considered favorable. Refer to **Table 3**.

Table 3. Goodness of fit of the model.

Model	CMIN	DF	<i>P</i>	CMIN/DF	GFI	AGFI	CFI	RMSEA
Default model	3.888	2	0.143	1.944	0.997	0.960	0.997	0.050
Saturated model	0.000	0	-	-	1.000	-	1.000	-
Independence model	700.024	21	0.000	33.334	0.665	0.553	0.000	0.290

Source: Compiled by authors.

Following the identification of a statistically significant relationship with ESGD, we proceeded to investigate if other aspects of ESGD quality had a similar impact on TBQ. ESGD was categorized into three distinct categories based on the average value of ESGD as the threshold. The average value of ESGD was around 51.127 out of 100.00 (with 50.00 being the reference point). Scores ranging from 50 + 10 were classified as A, scores ranging from 50–10 were classified as C, and scores ranging from 40–50 were classified as B. Companies with an ESGD score above 60 were designated as ESGD-A Rank, those with scores between 50-40 were designated as ESGD-B Rank, and those with scores below 40 were designated as ESGD-C Rank. A multi-group study is conducted to evaluate if the different ranks of ESGD (A, B, and C) have an influence on other variables, specifically TBQ and ROA, in the same direction.

The structural equation modeling of ESGD Ranks A, B, and C is displayed in **Figure 2**. Our analysis revealed that the earnings per share (EPS) and dividend yield (DA) of companies ranked A and B in terms of environmental, social, and governance (ESG) factors have a detrimental impact on TBQ. The EPS of firms ranked A and B in ESGD exhibited varying degrees of negativity towards TBQ. The standardized coefficient for company A was -0.15, with a statistical significance of 0.05. For company B, the standardized coefficient was -0.47, with a statistical significance of 0.001. Companies with an ESGD Rank C were shown to have a favorable impact on EPS to TBQ, with a standardized coefficient of 0.130 and a *p*-value of 0.110. However, the DA ratio was found to have no influence on TBQ. The companies with ESGD A and B ranks have an identical standardized regression weight of 0.44 to TBQ for their ROIC ratio. However, the C rank companies have a weaker regression weight. All these findings are statistically significant. The size of companies, as assessed by the natural logarithm of total assets (LnTA), exhibits a negative regression weight towards TBQ and ROA. The size of companies has a significant and adverse impact on TBQ, particularly in relation to the ESGD rank C. The primary determinant of Return on Assets (ROA) for companies ranked C in the ESGD index is the Return on Invested Capital (ROIC), with a standardized regression weight of 0.77, which is statistically significant at the 0.001 level. Refer to **Figure 2** and **Table 4**.

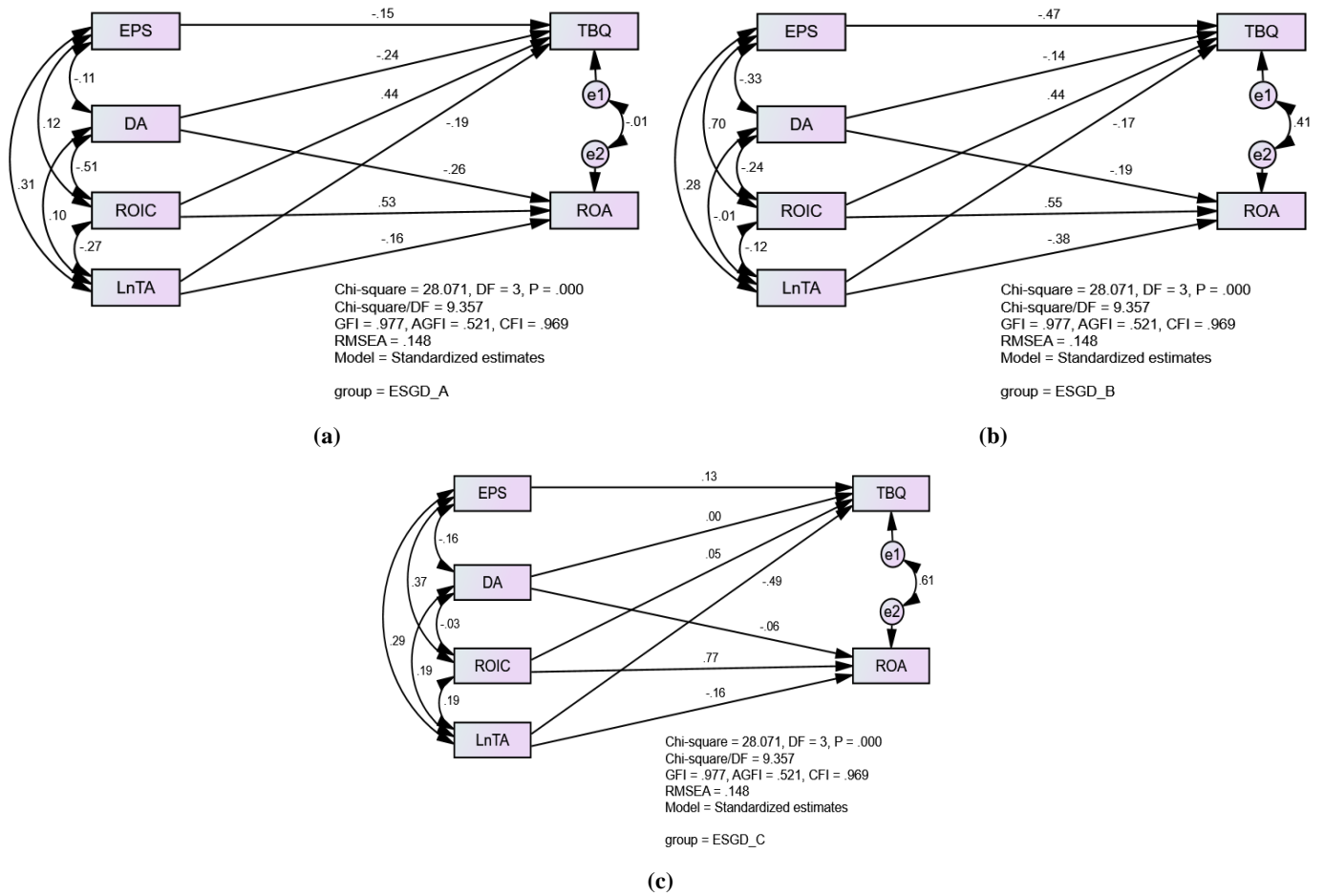

Figure 2. Structural equation modeling of ESGD A, B and C Ranks. **(a)** SEM of ESGD A Rank; **(b)** SEM of ESGD B Rank; **(c)** SEM of ESGD C Rank.

(Source: Compiled by authors).

Table 4. Comparative regression weights by ESGD A, B and C Ranks.

Path	ESGD-A Rank					ESGD-B Rank					ESGD-C Rank				
	USTD.	S.E.	C.R.	P	STD.	USTD.	S.E.	C.R.	P	STD.	USTD.	S.E.	C.R.	P	STD.
TBQ → EPS	-0.029	0.015	-1.969	0.049	-0.148	-0.086	0.019	-4.499	***	-0.467	0.133	0.083	1.600	0.110	0.130
TBQ → DA	-0.025	0.008	-2.960	0.003	-0.240	-0.008	0.004	-1.909	0.056	-0.135	0.000	0.008	0.006	0.995	0.001
ROA → DA	-0.065	0.018	-3.568	***	-0.259	-0.067	0.018	-3.709	***	-0.188	-0.032	0.037	-0.857	0.391	-0.057
TBQ → ROIC	0.127	0.025	5.171	***	0.439	0.048	0.011	4.389	***	0.444	0.006	0.012	0.514	0.607	0.049
ROA → ROIC	0.369	0.052	7.034	***	0.528	0.351	0.033	10.703	***	0.547	0.651	0.056	11.587	***	0.773
TBQ → LnTA	-0.275	0.115	-2.398	0.016	-0.186	-0.121	0.054	-2.240	.025	-0.174	-0.480	0.094	-5.093	***	-0.489
ROA → LnTA	-0.574	0.232	-2.480	0.013	-0.161	-1.599	0.208	-7.705	***	-0.382	-1.115	0.460	-2.425	0.015	-0.165

Note: USTD: Unstandardized; S.E.: Standard Error; C.R.: Critical ratio; P: P-value; STD: Standardized. *** significant at 0.001.
 (Source: Compiled by authors).

The notable discovery from the ESGD rank (**Table 4**) reveals that certain factors, specifically the DA (debt to assets) ratio of enterprises with ESGD C rank, were shown to lack statistical significance in relation to their profitability. The statistical significance of ROIC to ROA is similarly determined to be insignificant. The primary characteristics that have the most influence on organizations with an ESGD C rank are Return on Invested Capital (ROIC), company size, and Earnings Per Share (EPS). The profitability of DA is unrelated; however, it varies for companies ranked A and B in ESGD.

The results of this investigation provide a thorough answer to the suggested hypotheses. Firstly, Hypothesis 1, which proposes a favorable influence of ESGD on company performance, is partially validated. The research demonstrates a direct relationship between ESGD and TBQ, confirming the idea that through ESG policies improve investor confidence and market value. Nevertheless, the results indicate that there is no substantial correlation between ESGD and ROA. This implies that the beneficial effects of ESG disclosures may be more intricate and limited to particular financial indicators.

The study strongly supports Hypothesis 2. The statement illustrates that the influence of ESGD on company performance differs considerably according to the extent of disclosure. When examining the degrees of ESGD, namely high, medium, and low, it becomes apparent that high and medium levels of ESGD are associated with a detrimental effect on TBQ when there is an increase in EPS. On the other hand, low levels of ESGD exhibit a positive association. This finding substantiates the idea that the depth and quality of ESGD play a pivotal role in determining their impact on business performance. The varied effects of ESG on corporate outcomes demonstrate the intricate nature of its influence, affirming that not all ESG disclosures have an equal impact on firm financial success.

The correlation between ESGD and firm performance is intricate and influenced by a variety of factors, as evidenced by the diverse results from prior studies. The identification of a negative ESGD presented by Khandelwal et al. (2023) challenges the universally positive view proposed by signaling theory, suggesting that excessive disclosure or misaligned ESG practices could result in skepticism or disapproval from stakeholders. Likewise, the diverging impacts of ESGD in distinct geographical settings underscore the significance of taking into account cultural and regulatory frameworks, as demonstrated by variations in ESG effects between European and Asian companies. These findings emphasize the nuanced nature of ESG's influence and propose that a uniform approach may not be suitable. Consequently, forthcoming research should delve deeper into the circumstances under which ESGD enhance firm performance, considering the specific elements of ESG practices that are most esteemed by stakeholders in different contexts. By further exploring these dimensions, researchers can unveil the exact mechanisms by which ESGD affect firm performance and offer more precise guidance for practitioners aiming to strengthen their ESG strategies in alignment with stakeholder expectations and market requirements. The outcomes of this study, when juxtaposed with established theoretical frameworks, provide valuable insights and deviations that enrich our comprehension of ESGD's impact on firm performance. Viewed through the lens of stakeholder theory, the partial validation of Hypothesis 1, indicating a positive impact of ESGD on particular

financial metrics like TBQ, aligns with the notion that addressing broader stakeholder concerns—beyond shareholders alone—can boost company value (Bagh et al., 2024; Salehi and Alkhyoon, 2022). This discovery underscores the theory's argument that stakeholder involvement, facilitated by transparent ESG practices, can result in enhanced financial performance, showcasing stakeholders' recognition of sustainable and ethical business approaches. In the context of agency theory, the differential influence of ESGD on financial performance indicators, such as the absence of a significant correlation with ROA, may exemplify the intricate process of aligning manager and shareholder interests through ESG practices (Bagh et al., 2023). Although ESGD can mitigate information disparities and align interests to some degree, the findings propose that this alignment does not invariably translate into improved performance across all financial metrics. This disparity warrants further investigation into the types of ESG information most pertinent for reducing agency expenses and the circumstances under which such disclosures can effectively align stakeholders' interests. The study outcomes also interact with legitimacy theory, particularly through the nuanced execution and reception of ESG practices across diverse regions and sectors. The mixed results, spanning from favorable to adverse impacts on firm performance, mirror the varying degrees to which companies conform to societal norms and expectations through their ESG endeavors (Al-Khouri and Basith, 2022; Nuhu and Alam, 2024). This diversity implies that legitimacy is not universally conferred via ESGD; instead, it is reliant on the cultural, regulatory, and market milieus, underscoring the significance of tailored ESG approaches to uphold societal acceptance and legitimacy.

Lastly, the results are in line with signaling theory, particularly when considering the diverse impacts of varying degrees of ESG disclosure on corporate performance. The favorable outcomes linked to minimal ESG disclosure levels, in contrast to the adverse consequences at higher levels, may suggest a multifaceted signaling landscape where stakeholders interpret ESG reports from different perspectives (Wasiuzzaman et al., 2022). This indicates that the caliber, pertinence, and genuineness of ESG data could have a pivotal role in signaling a company's worth, whereby excessive or unfocused disclosures could potentially result in doubt or information overload. Consequently, these observations propose that although ESGD can enhance company performance as envisaged by theoretical frameworks, the correlation is intricate and influenced by factors like the extent of disclosure, stakeholder anticipations, and situational variables. The study emphasizes the necessity for a strategic ESG disclosure approach that is customized to meet the specific anticipations of diverse stakeholder segments and harmonized with the overarching business strategy of the company.

5. Conclusion and suggestion

The study's findings make a substantial contribution to the continuing academic discourse regarding the correlation between ESGD and business profitability. The study demonstrates a statistically significant correlation between the disclosure of ESG information and a company's profitability. Specifically, it emphasizes the impact of Earnings Per Share (EPS) and Debt to Asset ratio (DA) on Tobin's Q (TBQ). This

finding aligns with prior research conducted by Makhdalena et al. (2023), Seker and Şengür (2021), and Suttipun and Dechthanabodin (2022). These studies indicate that an increase in ESGD has a beneficial effect on TBQ, a crucial measure for assessing a company's market position and worth in terms of replacement.

Significantly, the study uncovers a detrimental effect of EPS and DA on TBQ, suggesting that elevated levels in these domains may result in a decrease in TBQ. On the other hand, it has been observed that ESGD, Return on Invested Capital (ROIC), and Log of Total Assets (LnTA) have a favorable impact on TBQ. The aforementioned highlights the significance of maintaining a well-proportioned financial framework to augment corporate profitability, indicating that an overreliance on debt or liabilities may compromise it. Additionally, the study highlights that larger corporations do not always experience advantages in terms of economies of scale, since smaller companies can take advantage of specialized markets and demonstrate greater agility in responding to uncertainty (Narula, 2020; Skordoulis et al., 2020).

The rankings for ESGD vary greatly, indicating a wide range of dedication and disclosure regarding ESG issues among the companies. The average score is slightly above 50, suggesting a moderate to high level of ESGD. The ESG disclosure was thoroughly examined using histogram and boxplot analyses, revealing that the scores are concentrated within the range of 40 to 60. Consequently, this range serves as a benchmark for dividing the scores into three distinct categories. Rank A indicates companies with ESG disclosure ratings above 60, while B represents scores ranging from 40 to 60, and C denotes scores below 40. The differentiation exposed diverse effects on TBQ across various levels of ESGD. Companies with high and medium ESGD rankings have a detrimental effect on TBQ when EPS grows. On the other hand, companies with low ESGD rankings observe a gain in TBQ as EPS rises. These findings are consistent with recent studies (Khandelwal et al., 2023; Kurniawan and Rokhim, 2023; Mendirartta et al., 2023; Palupi, 2023; Wei and Jiang, 2023), which suggest that greater levels of transparency can result in diminished profits in comparison to companies with lower levels of disclosure. The study also indicates that smaller companies experience greater advantages in terms of ROA when there are rises in ROIC, a trait that is more noticeable in smaller firms as compared to larger ones.

The correlation between ESGD and specific financial performance indicators, as emphasized in this study, advocates for policymakers to promote transparency and standardized reporting of ESG activities (Nuhu and Alam, 2024; Salehi and Alkhyoon, 2022). This can be facilitated by establishing and enforcing comprehensive ESG reporting frameworks, which would enhance transparency in the market and encourage sustainable business behaviors (Alsayegh et al., 2020; Papoutsis and Sodhi, 2020). Moreover, adopting a tiered approach to ESG reporting, as recommended by the research findings, would address the varying capacities of companies, ensuring that smaller firms are not burdened (Bagh et al., 2023; Hill, 2020; Dkhili, 2023). This strategy aligns with the scholarly call for policies that cater to the distinct needs and obstacles of different industry sectors (Al-Maliki et al., 2023). Finally, the diverse impacts of ESGD in different geographical areas highlight the significance of international policymakers striving to standardize ESG criteria, while allowing for regional adjustments to accommodate local customs and promote global

sustainable development (Chevrollier et al., 2020; Wasiuzzaman et al., 2022; Zumente and Bistrova, 2021).

The results of this study offer empirical validation to stakeholder theory by demonstrating how addressing various stakeholder concerns through ESG practices can lead to enhanced financial results, in line with prior research (Al-Maliki et al., 2023; Bagh et al., 2024). However, the complexity revealed by the mixed impacts of extensive ESGD suggests avenues for further theoretical investigation, particularly regarding stakeholder perceptions of ESG information (Camilleri, 2015; Matos, 2020). Concerning agency theory, the diverse effects of ESGD on different financial metrics challenge the idea that these disclosures alone can effectively mitigate agency conflicts, necessitating a reassessment of the circumstances under which ESG practices can reduce information asymmetry (Bagh et al., 2023; Carnini Pulino et al., 2022; Chen and Xie, 2022; Salehi and Alkhyoon, 2022). This study also enriches legitimacy theory by indicating that the efficacy of ESG practices in upholding a firm's legitimacy is influenced by various factors, including cultural, regulatory, and market contexts (Al-Khouri and Basith, 2022; Nuhu and Alam, 2024). This underscores the necessity of a broader theoretical framework that considers the diverse conditions affecting corporate legitimacy, aligning with the arguments put forth by Giannarakis et al. (2014) and Sciarelli et al. (2021). The findings reveal that societal legitimacy through ESG compliance hinges on meeting societal expectations, which can significantly differ across various contexts. Lastly, the study refines signaling theory by indicating that the signaling value of ESGD is shaped by the depth and quality of the disclosed information (Salehi et al., 2018; Wasiuzzaman et al., 2022). These challenges and current theoretical perspectives propose a more intricate understanding of how stakeholders interpret ESGD. These theoretical implications, backed by the findings of this study and existing literature, emphasize the importance of sustained scholarly exploration into the nuanced interplay between ESG practices, stakeholder involvement, and firm performance.

This investigation has shed light on the intricate relationship between ESGD and company performance, emphasizing the importance of transparency, engagement with stakeholders, and awareness of the context in corporate sustainability endeavors. The implications drawn from this research highlight the necessity for the creation of detailed ESG reporting guidelines and frameworks tailored to various corporate settings and stakeholder expectations. Nevertheless, the diverse effects of ESGD in different situations and the complex mechanisms call for additional empirical and theoretical investigation. Subsequent research should strive to unravel the specific circumstances in which ESG practices most significantly contribute to the success of companies and the well-being of society. By enhancing our comprehension of these dynamics, both academics and professionals can more effectively navigate the changing landscape of corporate accountability and sustainability.

Author contributions: Conceptualization, KT, GW, TK, PL and AR; methodology, KT, GW, TK and PL; software, KT, GW and TK; validation, KT, GW, TK and PL; formal analysis, KT, GW, TK and PL; investigation, KT, GW, TK, PL and AR; resources, KT, GW, TK, PL and AR; data curation, KT, GW, TK and PL; writing—original draft preparation, KT, GW, TK, PL and AR; writing—review and editing, KT,

GW, TK, PL and AR; visualization, KT, GW, TK and PL; supervision, KT, GW and TK; project administration, KT, GW and TK; funding acquisition, KT, GW and TK. All authors have read and agreed to the published version of the manuscript.

Conflict of interest: The authors declare no conflict of interest.

References

- Al-Khouri, R., & Abdul Basith, A. A. (2022). The Status of Environmental, Social, and Governance Voluntary Disclosure in the GCC Banking Industry: Does It Pay to Be Socially Responsible? *Empirical Research in Banking and Corporate Finance*, 155–189. <https://doi.org/10.1108/s1569-373220220000021006>
- Al-Maliki, R., Salehi, M., & Kardan, B. (2023). The relationship between managerial entrenchment, social responsibility, and firm's risk-taking and shareholders' activity. *Social Responsibility Journal*, 18(5), 1035-1049.
- Alsayegh, M. F., Abdul Rahman, R., & Homayoun, S. (2020). Corporate Economic, Environmental, and Social Sustainability Performance Transformation through ESG Disclosure. *Sustainability*, 12(9), 3910. <https://doi.org/10.3390/su12093910>
- Arianpoor, A., Salehi, M., & Daroudi, F. (2023). Nonfinancial sustainability reporting, management legitimate authority and enterprise value. *Social Responsibility Journal*, 19(10), 1900–1916. <https://doi.org/10.1108/srj-09-2022-0374>
- Arvidsson, S., & Dumay, J. (2022). Corporate ESG reporting quantity, quality and performance: Where to now for environmental policy and practice? *Business Strategy and the Environment*, 31(3), 1091–1110. Portico. <https://doi.org/10.1002/bse.2937>
- Bagh, T., Fuwei, J., & Khan, M. A. (2024). From risk to resilience: Climate change risk, ESG investments engagement and Firm's value. *Heliyon*, 10(5), e26757. <https://doi.org/10.1016/j.heliyon.2024.e26757>
- Bagh, T., Naseer, M. M., Khan, M. A., et al. (2023). Sustainable growth rate, corporate value of US firms within capital and labor market distortions: The moderating effect of institutional quality. *Oeconomia Copernicana*, 14(4), 1211–1255. <https://doi.org/10.24136/oc.2023.036>
- Barko, T., Cremers, M., & Renneboog, L. (2021). Shareholder Engagement on Environmental, Social, and Governance Performance. *Journal of Business Ethics*, 180(2), 777–812. <https://doi.org/10.1007/s10551-021-04850-z>
- Bloomberg Professional Services. (2022). Available online: <https://www.bloomberg.com/professional/blog/how-bloomberg-is-applying-its-data-expertise-to-esg/> (accessed on 2 January 2024).
- Camilleri, M. A. (2015). Environmental, social and governance disclosures in Europe. *Sustainability Accounting, Management and Policy Journal*, 6(2), 224–242. <https://doi.org/10.1108/sampj-10-2014-0065>
- Carnini Pulino, S., Ciaburri, M., Magnanelli, B. S., et al. (2022). Does ESG Disclosure Influence Firm Performance? *Sustainability*, 14(13), 7595. <https://doi.org/10.3390/su14137595>
- Chen, Z., & Xie, G. (2022). ESG disclosure and financial performance: Moderating role of ESG investors. *International Review of Financial Analysis*, 83, 102291. <https://doi.org/10.1016/j.irfa.2022.102291>
- Chevrollier, N., Zhang, J., van Leeuwen, T., et al. (2020). The predictive value of strategic orientation for ESG performance over time. *Corporate Governance: The International Journal of Business in Society*, 20(1), 123–142. <https://doi.org/10.1108/cg-03-2019-0105>
- Dkhili, H. (2023). Does environmental, social and governance (ESG) affect market performance? The moderating role of competitive advantage. *Competitiveness Review: An International Business Journal*, 34(2), 327–352. <https://doi.org/10.1108/cr-10-2022-0149>
- Donaldson, T., & Preston, L. E. (1995). The Stakeholder Theory of the Corporation: Concepts, Evidence, and Implications. *The Academy of Management Review*, 20(1), 65. <https://doi.org/10.2307/258887>
- Dowling, J., & Pfeffer, J. (1975). Organizational Legitimacy: Social Values and Organizational Behavior. *The Pacific Sociological Review*, 18(1), 122–136. <https://doi.org/10.2307/1388226>
- Freeman, R. E. (2010). *Strategic management: A stakeholder approach*. Cambridge University Press.
- Giannarakis, G., Konteos, G., & Sariannidis, N. (2014). Financial, governance and environmental determinants of corporate social responsible disclosure. *Management Decision*, 52(10), 1928–1951. <https://doi.org/10.1108/md-05-2014-0296>
- Harrison, J. S., & Wicks, A. C. (2013). Stakeholder Theory, Value, and Firm Performance. *Business Ethics Quarterly*, 23(1), 97–124. <https://doi.org/10.5840/beq20132314>
- Hill, J. (2020). *Environmental, Social, and Governance (ESG) investing: A balanced analysis of the theory and practice of a sustainable portfolio*. Academic Press.

- Hoang, T. (2018). The role of the integrated reporting in raising awareness of environmental, social and corporate governance (ESG) performance. In: *Stakeholders, Governance and Responsibility*. Emerald Publishing Limited.
- Hua, Y. (2022). How corporate ESG performance affects green supply chain management. *BCP Business & Management*, 25, 550–559. <https://doi.org/10.54691/bcpbm.v25i.1881>
- Huang, D. Z. X. (2022). An integrated theory of the firm approach to environmental, social and governance performance. *Accounting & Finance*, 62, 1567-1598.
- Hummel, K., & Schlick, C. (2016). The relationship between sustainability performance and sustainability disclosure – Reconciling voluntary disclosure theory and legitimacy theory. *Journal of Accounting and Public Policy*, 35(5), 455–476. <https://doi.org/10.1016/j.jaccpubpol.2016.06.001>
- Kenny, F., Nurcholifah, S., & Pulungan, A. H. (2022). Disclosure of environmental, social, and governance on firm performance pre and post introduction of integrated reporting: Evidence from ASEAN countries. *International Journal of Energy Economics and Policy*, 12(6), 377.
- Khandelwal, V., Sharma, P., & Chotia, V. (2023). ESG Disclosure and Firm Performance: An Asset-Pricing Approach. *Risks*, 11(6), 112. <https://doi.org/10.3390/risks11060112>
- Kurniawan, I., & Rokhim, R. (2023). Is ESG Companies' Performance Influenced by Ownership Structure? Evidence in ASEAN. *Interdisciplinary Social Studies*, 2(9), 2397–2413. <https://doi.org/10.55324/iss.v2i9.485>
- Laplume, A. O., Sonpar, K., & Litz, R. A. (2008). Stakeholder Theory: Reviewing a Theory That Moves Us. *Journal of Management*, 34(6), 1152–1189. <https://doi.org/10.1177/0149206308324322>
- Lowry, P. B., & Gaskin, J. (2014). Partial Least Squares (PLS) Structural Equation Modeling (SEM) for Building and Testing Behavioral Causal Theory: When to Choose It and How to Use It. *IEEE Transactions on Professional Communication*, 57(2), 123–146. <https://doi.org/10.1109/tpc.2014.2312452>
- Magness, V. (2006). Strategic posture, financial performance and environmental disclosure. *Accounting, Auditing & Accountability Journal*, 19(4), 540–563. <https://doi.org/10.1108/09513570610679128>
- Makhdalena., Zulvina, D., Zulvina, Y., et al. (2023). Environmental, Social, Governance, and Firm Performance in Developing Countries: Evidence from Southeast Asian. *Etikonomi*, 22(1), 65–78. <https://doi.org/10.15408/etk.v22i1.25271>
- Marcoulides, K. M., & Yuan, K. H. (2017). New ways to evaluate goodness of fit: A note on using equivalence testing to assess structural equation models. *Structural Equation Modeling: A Multidisciplinary Journal*, 24(1), 148–153. <https://doi.org/10.1080/10705511.2016.1225260>
- Matos, P. (2020). ESG and responsible institutional investing around the world: A critical review. CFA Institute Research Foundation.
- Means, G. (2017). *The modern corporation and private property*. Routledge.
- Meckling, W. H., & Jensen, M. C. (1976). Theory of the firm: Managerial behavior, agency costs and ownership structure. *Journal of Financial Economics*, 3(4), 305-360.
- Mendiratta, A., Singh, S., Yadav, S. S., & Mahajan, A. (2023). ESG Controversies and Firm Performance in India: The Moderating Impact of Government Effectiveness. *Global Business Review*, 09721509231151490.
- Narula, R. (2020). Policy opportunities and challenges from the COVID-19 pandemic for economies with large informal sectors. *Journal of International Business Policy*, 3(3), 302-310.
- Nuhu, Y., & Alam, A. (2024). Board characteristics and ESG disclosure in energy industry: Evidence from emerging economies. *Journal of Financial Reporting and Accounting*, 22(1), 7–28. <https://doi.org/10.1108/jfra-02-2023-0107>
- Palupi, A. (2023). Does ESG Affect the Firm Value? *Accounting & Finance Review*, 7(4), 19-26.
- Papoutsis, A., & Sodhi, M. S. (2020). Does disclosure in sustainability reports indicate actual sustainability performance? *Journal of Cleaner Production*, 260, 121049. <https://doi.org/10.1016/j.jclepro.2020.121049>
- Passetti, E., Cinquini, L., & Tenucci, A. (2018). Implementing internal environmental management and voluntary environmental disclosure. *Accounting, Auditing & Accountability Journal*, 31(4), 1145–1173. <https://doi.org/10.1108/aaaj-02-2016-2406>
- Peng, L. S., & Isa, M. (2020). Environmental, social and governance (ESG) practices and performance in Shariah firms: agency or stakeholder theory? *Asian Academy of Management Journal of Accounting & Finance*, 16(1), 1-34.
- Phoprachak, D., Buntornwon, T. (2020). Influence of Firm Size on the Environmental Disclosure and Performance of the Listed Companies on the Stock Exchange of Thailand. In: Díaz Díaz, B., Capaldi, N., Idowu, S. O., Schmidpeter, R. (editors). *Responsible Business in a Changing World. CSR, Sustainability, Ethics & Governance*. Springer, Cham.

- Salehi, M., & Alkhyoon, H. (2022). The relationship between managerial entrenchment, social responsibility, and firm's risk-taking and shareholders' activity. *Social Responsibility Journal*, 18(5), 1035–1049. <https://doi.org/10.1108/srj-10-2019-0339>
- Salehi, M., Lari DashtBayaz, M., & Khorashadzadeh, S. (2018). Corporate social responsibility and future financial performance. *EuroMed Journal of Business*, 13(3), 351–371. <https://doi.org/10.1108/emjb-11-2017-0044>
- Schaltegger, S., & Wagner, M. (2011). Sustainable entrepreneurship and sustainability innovation: categories and interactions. *Business Strategy and the Environment*, 20(4), 222–237. Portico. <https://doi.org/10.1002/bse.682>
- Schot, J., & Steinmueller, W. E. (2018). Three frames for innovation policy: R&D, systems of innovation and transformative change. *Research Policy*, 47(9), 1554–1567. <https://doi.org/10.1016/j.respol.2018.08.011>
- Sciarelli, M., Cosimato, S., Landi, G., et al. (2021). Socially responsible investment strategies for the transition towards sustainable development: the importance of integrating and communicating ESG. *The TQM Journal*, 33(7), 39–56. <https://doi.org/10.1108/tqm-08-2020-0180>
- Şeker, Y., & Şengür, E. D. (2021). The Impact of Environmental, Social, and Governance (ESG) Performance on Financial Reporting Quality: International Evidence. *Ekonomika*, 100(2), 190–212. <https://doi.org/10.15388/ekon.2021.100.2.9>
- Shafeeq Nimr Al-Maliki, H., Salehi, M., & Kardan, B. (2023). The relationship between board characteristics and social responsibility with firm innovation. *European Journal of Management and Business Economics*, 32(1), 113–129. <https://doi.org/10.1108/ejmbe-04-2020-0094>
- Singhania, M., & Saini, N. (2023). Institutional framework of ESG disclosures: comparative analysis of developed and developing countries. *Journal of Sustainable Finance & Investment*, 13(1), 516–559. <https://doi.org/10.1080/20430795.2021.1964810>
- Skordoulis, M., Ntanos, S., Kyriakopoulos, G. L., et al. (2020). Environmental Innovation, Open Innovation Dynamics and Competitive Advantage of Medium and Large-Sized Firms. *Journal of Open Innovation: Technology, Market, and Complexity*, 6(4), 195. <https://doi.org/10.3390/joitmc6040195>
- Suttipun, M., & Dechthanabodin, P. (2022). Environmental, Social and Governance (ESG) Committees and Performance in Thailand. *Asian Journal of Business and Accounting*, 15(2), 205–220. <https://doi.org/10.22452/ajba.vol15no2.7>
- Tarmuji, I., Maelah, R., & Tarmuji, N. H. (2016). The Impact of Environmental, Social and Governance Practices (ESG) on Economic Performance: Evidence from ESG Score. *International Journal of Trade, Economics and Finance*, 7(3), 67–74. <https://doi.org/10.18178/ijtef.2016.7.3.501>
- Thanjunpong, S., Awirothananon, T., & Dechsiri, P. (2019). The Impact of Sustainable Development Report on Firm Performance in Thailand. *Journal of Accounting & Finance*, 19(3), 2158-3625.
- Trepongkaruna, S., & Suttipun, M. (2024). The impact of environmental, social and governance (ESG) reporting on corporate profitability: Evidence from Thailand. *Journal of Financial Reporting and Accounting*.
- Van Brecht, D., Maga, A., Luciani, K., et al. (2018). Exploring the link between environmental, social and governance (ESG) disclosure and market value of the firm: Evidence from Thai listed companies. *AJMI-ASEAN Journal of Management and Innovation*, 5(2), 95-106.
- Vizcarra, H. V. (2020). The reasonable investor and climate-related information: changing expectations for financial disclosures. *Environmental Law Reporter News & Analysis*, 50, 10106.
- Wasiuzzaman, S., Ibrahim, S. A., & Kawi, F. (2022). Environmental, social and governance (ESG) disclosure and firm performance: does national culture matter? *Meditari Accountancy Research*, 31(5), 1239–1265. <https://doi.org/10.1108/medar-06-2021-1356>
- West, S. G., Wu, W., McNeish, D., & Savord, A. (2023). Model fit in structural equation modeling. *Handbook of structural equation modeling*. The Guilford Press.
- Wicaksono, A. P. (2023). Environmental, Social, Governance and Firm Performance in Developing Countries: Evidence from Southeast Asian. *Etikonomi*, 22(1), 65-78.
- Wu, Y., & Tham, J. (2023). The Impact of Executive Green Incentives and Top Management Team Characteristics on Corporate Value in China: The Mediating Role of Environment, Social and Government Performance. *Sustainability*, 15(16), 12518. <https://doi.org/10.3390/su151612518>
- Zhang, C., & Jin, S. (2022). What drives sustainable development of enterprises? Focusing on ESG management and green technology innovation. *Sustainability*, 14(18), 11695.
- Zhang, P., Wei, J., & Jiang, J. (2023). ESG Information Disclosure and Corporate Earnings Management—Research on the Moderating Effect Based on Media Attention. *Journal of Education, Humanities and Social Sciences*, 16, 69-79.

Zumente, I., & Bistrova, J. (2021). ESG Importance for Long-Term Shareholder Value Creation: Literature vs. Practice. *Journal of Open Innovation: Technology, Market, and Complexity*, 7(2), 127. <https://doi.org/10.3390/joitmc7020127>