

Article

# Examine the interaction impact of psychological characteristics on individual entrepreneurial orientation and cyberpreneurship intentions

Mohammad Falahat\*, Arumugam G. Sithamparam, Nor Azrul Mohd Zin, Kok Meng Ng

School of Marketing and Management, Asia Pacific University of Technology and Innovation, Kuala Lumpur 57000, Malaysia

\* **Corresponding author:** Mohammad Falahat, [Mohammad.falahat@apu.edu.my](mailto:Mohammad.falahat@apu.edu.my)

## CITATION

Falahat M, Sithamparam AG, Mohd Zin NA, Ng KM (2024). Examine the interaction impact of psychological characteristics on individual entrepreneurial orientation and cyberpreneurship intentions. *Journal of Infrastructure, Policy and Development*. 8(4): 3381. <https://doi.org/10.24294/jipd.v8i4.3381>

## ARTICLE INFO

Received: 21 November 2023

Accepted: 18 December 2023

Available online: 13 March 2024

## COPYRIGHT



Copyright © 2024 by author(s). *Journal of Infrastructure, Policy and Development* is published by EnPress Publisher, LLC. This work is licensed under the Creative Commons Attribution (CC BY) license. <https://creativecommons.org/licenses/by/4.0/>

**Abstract:** In a rapidly evolving digital economy, cyberpreneurship has emerged as a pivotal force driving innovation and economic growth. The study applies the Theory of Planned Behaviour in predicting entrepreneurial intention in the context of Malaysia, where the government has actively championed digital entrepreneurship. Drawing from a sample of 473 final-year university students in the Klang Valley region of Malaysia, the study investigates the impact of Individual Entrepreneurial Orientation (IEO) dimensions, namely innovativeness, risk-taking, and proactiveness, on the intention to engage in cyberpreneurship within the context of Digital Free Trade Zones (DFTZ). The study further examines the moderation effect of psychological characteristics incorporating visionary thinking, self-efficacy, opportunism, and creativity to provide a comprehensive understanding of the factors influencing cyberpreneurial intentions. With the moderating variable, the paper presents a comprehensive model to investigate the IEO and psychological characteristics contributing to cyberpreneurship intentions and its impact on engagement in DFTZ. An empirical examination of data and hypotheses found that risk-taking (RISK) and proactiveness (PRO) are significantly related to cyberpreneurial intention. Psychological characteristics significantly proved its moderating role in its interaction with innovativeness (INNO), risk-taking (RISK), and proactiveness (PRO) in influencing cyberpreneurial intentions (CYBER\_PI). Innovativeness (INNO) without the influence of the moderating variable is not significantly related to cyberpreneurial intentions. Engagement with the Digital Free Trade Zone (DFTZ) through the mediating role of cyberpreneurial intentions (CYBER\_PI), the innovativeness (INNO) did not succeed. On the other hand, risk-taking (RISK) and proactiveness (PRO) are found to be significant. The paper contributes to the landscape of e-commerce and digital trade literature by advancing our understanding of the factors driving individuals' intentions to participate in cyberpreneurship and engage in DFTZ. The findings of this study provide valuable insights for policymakers, educators, and entrepreneurs alike.

**Keywords:** cyberpreneurship; entrepreneurial orientation; psychological characteristics; innovativeness; risk taking; proactiveness; visionary; self-efficacy; DFTZ

## 1. Introduction

In recent years, the proliferation of digital technologies has transformed the entrepreneurial landscape, offering new opportunities for individuals to engage in cyberpreneurship, which refers to the intention to become an entrepreneur in the digital realm. The emergence of a digital free trade zone (DFTZ) further facilitates cross-border e-commerce activities by providing a platform for seamless international trade. Understanding the factors that drive individuals' intentions to participate in cyberpreneurship is of paramount importance for both academic research and policy formulation. This study aims to achieve the following objectives: 1) examine the

impact of innovativeness, risk-taking, and proactiveness as dimensions of international Entrepreneurial Orientation (IEO) on cyberpreneurship; 2) investigate the moderating role of psychological characteristics (visionary thinking, self-efficacy, opportunism, and creativity) on the IEO dimensions and cyberpreneurship; 3) examine the mediating role of cyberpreneurship in the relationship between IEO dimensions and engagement in DFTZ.

## **2. Theoretical foundation**

The Theory of Planned Behavior (TPB), an extension of the Theory of Reasoned Action by Ajzen (1985), provides a robust theoretical foundation for examining entrepreneurial intentions. This theory is widely acknowledged for its effectiveness in predicting and explaining behavior in specific contexts, including entrepreneurship (Ajzen, 1991; Fayolle and Liñán, 2014; Taha et al., 2017; Sabah, 2016). TPB posits that human actions, particularly in entrepreneurship, are planned and stem from a cognitive process involving intentions (Renko et al., 2012; Linan, 2008). Davidson (2004) further emphasizes that entrepreneurial intention is crucial for venture creation, suggesting a direct correlation between intention and entrepreneurial activities.

Several studies have evaluated and demonstrated the explanatory value of the TPB model in describing behavioral intention and actual behavior in fields such as social science and marketing, amongst them are Aloulou (2016); Durac and Moga (2023); and Anderson (2023). The theory proposes that certain human actions are planned and, therefore, accompanied by the desire to act. It helps researchers better understand and predict entrepreneurial intent in the entrepreneurial setting by considering not only personal variables but also social factors in a closer and more relevant framework.

Behavioral intentions involve three determinants, as stated by the TPB model. The first is the attitude toward the behavior, which refers to the degree to which the individual has a positive or negative evaluation. The second determinant is the subjective norm, which refers to whether the behavior is to be performed by the perceived social pressure of family, friends, or peers. The third determinant is the perceived behavioral control that contributes to the perceived ease or complexity of the behavior being conducted. In other words, the greater the individual's control capabilities, the greater the intention to execute the behavior (Ajzen, 1991). It is important to know the consistency of these factors in predicting entrepreneurial intentions. As informed by Krueger et al., (2000), personal attitudes and perceived behavior control have consistently predicted entrepreneurial intentions but not the same for subjective norms (Anderson, 2023). The subjective norms factor which may not predict an entrepreneurial intention is quite not surprising as it hinges on social relationships outside oneself. The factors' relative importance in the prediction of intention is expected to vary across behaviors, situations, and contexts (Ajzen, 1991). Therefore, further study in different contexts should be done to validate the consistency of these factors and shed light on our understanding of the entrepreneurial process.

Our study integrates the TPB to examine the impact of individual traits-innovativeness, risk-taking, proactiveness and psychological characteristics on

cyberpreneurship intentions. This approach is informed by the TPB's focus on three key determinants: Attitude toward behavior, subjective norms, and perceived behavioral control.

**Attitude toward behavior:** This refers to the individual's positive or negative evaluation of entrepreneurial behavior. Our selection of variables like innovativeness, risk-taking, and proactiveness aligns with this determinant, as they embody the personal attitudes that shape one's view towards entrepreneurship.

**Subjective norms:** While TPB emphasizes the role of social pressures from family, friends, or peers, recent studies (e.g., Anderson, 2023) suggest that subjective norms may not consistently predict entrepreneurial intentions. This is particularly relevant in the context of cyberpreneurship, where individual decision-making may be more influenced by personal traits and market dynamics than by social pressures.

**Perceived behavioral control:** This determinant highlights the role of self-efficacy and perceived ease or difficulty of performing entrepreneurial activities. Our study's focus on psychological characteristics like visionary thinking, self-efficacy, opportunism, and creativity is closely aligned with this aspect of TPB. These traits are fundamental in shaping an individual's perceived control over entrepreneurial endeavors.

### **3. Hypothesis development**

The selection of these variables is theoretically grounded in TPB, as they represent key facets of an individual's attitude, perceived control, and, to a lesser extent, subjective norms. Our approach extends the application of TPB in entrepreneurship research by specifically focusing on cyberpreneurship and its relation to the Digital Free Trade Zone (DFTZ). This novel application of TPB in our study not only adheres to the theoretical model but also contributes to its expansion in the context of digital entrepreneurship.

#### **3.1. Individual entrepreneurial orientation (IEO)**

It is important to provide clarification as to whether EO (entrepreneurial orientation) is limited only to a firm. Covin et al. (2020) clarified and implied that EO may manifest at different levels. In recent years, studies have pointed toward the significance of understanding entrepreneurial orientation's attributes as individual entrepreneurial orientation (IEO) (Covin et al., 2020; Martin and Perez, 2020; Santos et al., 2020). Therefore, the authors as well as Bolton and Lane (2012) derived the entrepreneurial orientation as a tendency by firms or individuals towards innovative, proactive, and risk-taking behaviors. Parveen et al. (2015) in their study on social media usage and organizational performance, noted that for entrepreneurs to leverage the digital space and become cyberpreneurs, entrepreneurial orientation (EO) is vital and the argument concurs with Lumpkin and Dess (1996) who informed EO becomes a supportive force for entrepreneurs in embracing emerging technologies.

#### **3.2. Innovativeness**

Kraus et al. (2019) in the IEO context, innovativeness is about efforts indulged with something new and unknown. Abubakar et al. (2020) define personal

innovativeness in information technology as a person's willingness to engage with digital technological innovations for their entrepreneurial projects. One can derive that innovativeness may bring about positive intentions from the author's argument that higher personal innovativeness in information technology is more likely to bear favorable perceptions about new IT leading to having positive intentions. However, Abubakre et al. (2020) studied personal innovative as a moderator for the relationship between IT culture and successful digital entrepreneurship (DE). In this study, innovativeness is treated as a predictor of cyberpreneurship intentions. The intersection of innovativeness and cyberpreneurship intentions represents a compelling area of study in the contemporary entrepreneurial landscape. As the digital realm continues to evolve, individuals and businesses are increasingly drawn to the opportunities presented by cyberpreneurship, where innovative ideas find expression in the online space. This literature review explores the dynamic relationship between innovativeness and the intentions of individuals to engage in cyberpreneurial activities. Tsai (2018) studied innovation from the national culture perspective. The author regarded the innovation sense as critical for sustainable economic social development. Relating to the national culture perspective, the argument of Urbana et al. (2019) is relevant. The authors find that the national cultures encourage innovation and are more likely to foster a favorable social normative environment for technology entrepreneurship. Jia et al. (2022) studied institutional environment in the digital context affect technology entrepreneurship and found that innovative culture is associated with technology entrepreneurship.

Innovation, as a fundamental driver of economic growth and development, has gained prominence in scholarly discourse. Scholars have long emphasised the critical role of innovation in fostering entrepreneurial initiatives (Audretsch and Keilbach, 2004). When considering cyberpreneurship, the fusion of innovation and digital technology becomes particularly salient. Cyberpreneurship encompasses entrepreneurial activities conducted in the virtual sphere, ranging from e-commerce ventures to digital marketing initiatives (Lee et al., 2011). The digitisation of business processes creates a fertile ground for innovators to explore novel ways of delivering products and services, thereby influencing cyberpreneurship intentions.

The relationship between innovativeness and cyberpreneurship intentions is complex and multifaceted. One key aspect is the impact of technological advancements on the entrepreneurial mindset. The advent of disruptive technologies, such as blockchain, artificial intelligence, and the Internet of Things, has not only revolutionised business models but has also sparked entrepreneurial interest in harnessing these innovations for cyberpreneurial endeavors (Chesbrough, 2002). Entrepreneurs with a proclivity for innovativeness are more likely to be attracted to the dynamic and ever-evolving landscape of cyberpreneurship.

Furthermore, innovativeness plays a pivotal role in shaping the entrepreneurial mindset necessary for venturing into the digital realm. Individuals characterised by a high degree of innovativeness exhibit a willingness to explore uncharted territories, experiment with new ideas, and adapt to changing technological landscapes (Shane and Venkataraman, 2000). This predisposition aligns seamlessly with the challenges and opportunities inherent in cyberpreneurship, where staying abreast of technological advancements is imperative for success.

In the context of cyberpreneurship intentions, innovativeness contributes to the identification and exploitation of digital opportunities. Entrepreneurs who possess a strong innovativeness orientation are more likely to recognise gaps in the online market, envision novel solutions, and capitalise on emerging trends (Hernández-Perlines et al., 2019). This proactive approach to innovation not only fuels the initiation of cyberpreneurial activities but also sustains them in the face of rapid technological changes.

Moreover, the influence of innovativeness on cyberpreneurship intentions extends beyond individual characteristics to organisational dynamics. Innovative organisational cultures, characterised by a commitment to experimentation, continuous learning, and openness to new ideas, foster an environment conducive to cyberpreneurial initiatives. Organisations that prioritise innovativeness are better positioned to support and encourage employees to pursue cyberpreneurial ventures. Several authors including Koh (1996), and Gurol and Atsan (2006) found innovativeness does influence entrepreneurial intention.

In conclusion, the nexus between innovativeness and cyberpreneurship intentions represents a fertile ground for scholarly exploration. As the digital landscape continues to evolve, understanding how innovativeness influences the decision to engage in cyberpreneurial activities is crucial for both academics and practitioners. This literature review has shed light on the multifaceted relationship between innovativeness and cyberpreneurship intentions, emphasising the pivotal role of innovation in shaping the mindset and actions of individuals and organisations venturing into the dynamic realm of cyber entrepreneurship.

- H1: Innovativeness positively influences cyberpreneurship intentions.

### **3.3. Risk-taking**

Covin et al. (2020) defined risk taking as the “willingness to undertake tasks with uncertain outcomes”. Risk-taking represents an individual’s propensity to take calculated risks. Higher risk-taking individuals are more likely to embrace uncertainty, which can translate into a greater willingness to engage in cyberpreneurship, an endeavor with inherent risks. The ‘uncertain outcome’ as professed by Covin et al. (2020) is echoed by Davis et al. (2016), where the authors noted that risk-taking is the ability of individuals to implement plans or goals, even though they are mindful of the minimal chance of succeeding. Under unpredictable circumstances, entrepreneurial activities involve decision-making, which has resulted in a comparatively higher risk comparison to conventional salaried jobs (Kusmintarti et al., 2016). Risk-taking is thus perceived to be one of the most prominent attributes of an entrepreneur, which forces them to make crucial business judgments and participate in risky entrepreneurial practices with little or no information (Elali and Al-Yacoub, 2016).

The connection between risk-taking propensity and cyberpreneurship intentions is a nuanced and critical aspect of contemporary entrepreneurial research. Cyberpreneurship, inherently intertwined with the digital landscape, requires individuals to navigate a dynamic and often uncertain environment. This literature review delves into the intricate relationship between risk-taking behavior and the intentions of individuals to embark on cyberpreneurial ventures. Nikitina et al. (2022)

found that risk-taking and proactiveness seem to influence the inclination toward establishing an international entrepreneurial business venture. However, the authors as well as Kropp et al. (2008) did not find the same for innovativeness.

According to a study by Shepherd (2016), risk-taking propensity is a key factor in entrepreneurial decision-making, influencing the identification and pursuit of opportunities. In the context of cyberpreneurship, where the virtual terrain is rife with uncertainties, individuals with a higher tolerance for risk are more likely to perceive the dynamic digital environment as a fertile ground for innovation and venture creation. The study emphasises that risk-taking is not merely a trait but a dynamic process influenced by the interaction between individual characteristics and environmental factors.

Moreover, recent work by Hasbolah et al. (2020) underscore the role of risk perception in shaping cyberpreneurship intentions. The study highlights that individuals who accurately assess and manage the risks associated with online ventures are more likely to exhibit a positive intention to engage in cyberpreneurial activities. This aligns with the notion that successful cyberpreneurs are not risk-averse but rather possess the ability to evaluate and navigate risks strategically in the digital landscape.

The study by Hasbolah et al. (2020) also draw attention to the contextual nature of risk-taking in cyberpreneurship. Regional variations and cultural attitudes toward risk play a significant role in shaping individuals' perceptions and responses to the uncertainties inherent in online business endeavors. In conclusion, the latest research emphasises the continued relevance of risk-taking in shaping cyberpreneurship intentions, offering insights into the complex interplay of individual traits, environmental factors, and cultural influences in the digital entrepreneurial landscape.

- H2: Risk-taking positively influences cyberpreneurship intentions.

### **3.4. Proactiveness**

Proactiveness indicates an individual's tendency to take initiative and act ahead of time. Such individuals are likely to actively seek out opportunities, making them more predisposed to engage in cyberpreneurship. Proactivity at the personal level corresponds to their desire to predict the future by looking at potential business opportunities and launching new goods or brands in advance of their rivals (Alam et al., 2015). Proactive characteristics are linked to the rivals of entrepreneurs, they are driven to be the first mover on the market and have a predominant role in being competitive in the sector. Park (2017) has stated that proactive entrepreneurs are active in combating their rivals and are aggressive in delivering new goods or services to the market. According to Linton (2019), and Jin et al. (2017), proactivity can be described as the first breakthrough in the industry, and the main purpose of a proactive entrepreneur is to overtake its rivals by introducing innovations, forecasting the future market, and generating prospects for progress that will shape the market. Proactive individuals are more likely to recognise and seize digital entrepreneurial opportunities, leading to higher cyberpreneurial intentions. As mentioned above, EO is vital for cyberpreneurship. Kropp et al. (2007) examined the three elements of an entrepreneurial orientation (proactiveness, innovativeness, and risk-taking) and found

that proactiveness and risk-taking seem to be significantly related to entrepreneurial orientation. The findings concurred with Lee and Peterson (2000) who noted that both elements are important dimensions of entrepreneurial orientation. Yildirim-Oktem et al. (2023) have adopted the elements-innovativeness, proactiveness, and risk-taking, of entrepreneurial orientation in their study on the effect of environmental dynamism on entrepreneurial orientation in family firms.

As the landscape of entrepreneurship continues to evolve in the digital era, the role of proactiveness in shaping cyberpreneurship intentions has garnered increased attention. Proactiveness, defined as the willingness to take initiative, anticipate opportunities, and act on them (Bateman and Crant, 1993), is considered a crucial trait for individuals navigating the dynamic and fast-paced realm of cyberpreneurship.

Recent research by Wang and Altinay (2012) delves into the intricate relationship between proactiveness and cyberpreneurship intentions. The study emphasises that individuals characterised by a proactive orientation are more likely to identify and capitalise on opportunities in the digital sphere. In the context of cyberpreneurship, where innovation and agility are paramount, a proactive mindset becomes a distinguishing factor in the decision to initiate and sustain entrepreneurial activities online.

Furthermore, proactiveness is closely linked to the ability to adapt to technological advancements. The study by Wang and Altinay (2012) suggests that individuals with a proactive stance are better equipped to navigate the ever-changing landscape of digital technologies, allowing them to stay ahead of the curve in terms of online business trends and opportunities. This aligns with the notion that cyberpreneurs, by nature, need to be forward-thinking and adaptive to succeed in the competitive digital environment.

In addition, the study highlights the impact of proactiveness on the entrepreneurial process, emphasising that proactive individuals are more likely to engage in opportunity-seeking behaviors and exhibit a positive intention to venture into cyberpreneurship. This proactive approach extends beyond mere reaction to market trends; it involves actively seeking out and creating opportunities in the digital space, contributing to the continuous evolution of the online entrepreneurial landscape.

As the digital business environment continues to evolve, individuals with a proactive mindset are better positioned to not only identify opportunities but also to proactively shape and contribute to the growth of the cyberpreneurial ecosystem. Understanding the impact of proactiveness on cyberpreneurship intentions is crucial for researchers and practitioners alike in navigating the complexities of the digital entrepreneurial landscape. Thus, we propose below hypotheses:

- H3: Proactiveness positively influences cyberpreneurship intentions.

### **3.5. Cyberpreneurship and engagement in DFTZ**

#### **3.5.1. Dependent Variable (DV): Engagement in the DFTZ**

DFTZ represents involvement in the Digital Free Trade Zone initiative. This study argues that involvement with cyberpreneurship leads to engagement in DFTZ, as individuals who possess intentions to become digital entrepreneurs are more likely

to utilise the resources and opportunities provided by DFTZ to establish and expand their online business activities.

Cyberpreneurial intentions are expected to positively influence an individual's engagement in a digital free trade zone. Individuals who intend to become cyberpreneurs are inherently motivated to explore avenues that facilitate their digital entrepreneurial activities. DFTZ, which is designed to support cross-border e-commerce, offers a range of resources and services that align with the goals of aspiring cyberpreneurs. The electronic world trade platform (e-WTP), which is part of the DFTZ avenue for Small and Medium Enterprises (SMEs) to initiate export efforts, and its knowledge and facilities likely motivate aspiring entrepreneurs. The e-WTP is committed to providing a conducive environment for online businesses. The DFTZ would drive to sow seeds of cyberpreneurship through its enabling facilities to connect to eMarketplaces, government agencies, cross-border logistics providers, and cross-border payment providers. Individuals to engage in digital entrepreneurship are more likely to take advantage of the opportunities and facilities provided by DFTZ. This relationship highlights the practical application of individuals' intentions in leveraging the resources of the Digital Free Trade Zone to further their entrepreneurial pursuits in the digital realm.

The research delves into the nexus between Cyberpreneurship intentions and active participation in the Digital Free Trade Zone. The study suggests that individuals or businesses with clear intentions to engage in Cyberpreneurship are more likely to leverage and contribute to the opportunities presented by the DFTZ. Cyberpreneurial endeavors, by nature, involve the utilisation of digital platforms and technologies, aligning seamlessly with the objectives of DFTZ to promote cross-border e-commerce and digital connectivity.

Moreover, the study highlights that Cyberpreneurship intentions positively influence the adoption of digital trade practices within the DFTZ framework. Entrepreneurs and businesses with a commitment to digital innovation and online ventures are more inclined to explore and exploit the benefits offered by the DFTZ in terms of streamlined customs procedures, reduced trade barriers, and enhanced digital infrastructure.

The work emphasises that Cyberpreneurship intentions go beyond individual aspirations and extend to the broader economic landscape. Entrepreneurs with intentions to engage in Cyberpreneurship contribute to the overall growth and vibrancy of the digital economy, aligning with the goals of DFTZ to establish a conducive environment for digital trade and entrepreneurship.

As the digital landscape continues to reshape the way business is conducted globally, understanding how entrepreneurial intentions in the cyber realm contribute to and align with initiatives like DFTZ is essential for policymakers, researchers, and practitioners seeking to foster a robust and inclusive digital economy. Thus, we propose the below hypothesis:

- H4: Cyberpreneurship intentions positively influence engagement in DFTZ.

The study by Jiao et al. (2022) is interesting, in that it was found that the government degree of digitalization, when it is higher, there will be a weaker positive relationship between exposure to digital networks and technology entrepreneurship.



### **3.5.2. Mediating Variable (MV): Cyberpreneurship**

Cyberpreneurship captures the intention to become an entrepreneur in the digital space. It serves as a mediating variable, meaning that it is expected to explain the mechanism through which IEO dimensions (innovativeness, risk-taking, proactiveness) influence engagement in the DFTZ through the mediating effect of Cyberpreneurship. Thus, we propose below hypotheses:

- H5: Cyberpreneurship intentions mediate the relationship between innovativeness and engagement in DFTZ.
- H6: Cyberpreneurship intentions mediate the relationship between risk-taking and engagement in DFTZ.
- H7: Cyberpreneurship intentions mediate the relationship between proactiveness and engagement in DFTZ.

### **3.5.3. Moderating Variables (MVs): Psychological characteristics**

Visionary thinking, self-efficacy, opportunism, and creativity are conceptualised as psychological characteristics that moderate the relationship between IEO dimensions and cyberpreneurial intentions. Visionary thinking reflects an individual's ability to think creatively and envision future possibilities (Preller et al., 2020). It is anticipated that individuals with higher levels of visionary thinking will enhance the positive relationship between IEO dimensions and cyberpreneurial intentions, as they can perceive novel ways to leverage their entrepreneurial orientation in the digital realm.

Self-efficacy refers to an individual's belief in their capabilities to execute tasks successfully (Ngoc Khuong and Huu An, 2016). Individuals with high self-efficacy are more likely to translate their entrepreneurial orientation into cyberpreneurial intentions because they have confidence in their ability to navigate the challenges of the digital business landscape. It implies the judgment of their skill by the individuals if they can implement the target actions. As individuals with a high level of self-efficacy tend to perceive themselves as capable and willing to resolve any obstacles or problems in entrepreneurial practices, they will have a higher possibility of engaging in entrepreneurship and even international business (Elali and Al-Yacoub, 2016).

Opportunism signifies an individual's tendency to seize advantageous situations. Those who exhibit high levels of opportunism are likely to recognise and capitalise on opportunities within the digital ecosystem, further amplifying the link between IEO dimensions and cyberpreneurial intentions.

Creativity represents an individual's capacity to generate novel ideas and solutions. Individuals with higher levels of creativity are expected to amplify the positive relationship between IEO dimensions and cyberpreneurial intentions, as they can envision innovative ways to channel their entrepreneurial orientation into digital entrepreneurship.

Visionary thinking, self-efficacy, opportunism, and creativity are hypothesised to moderate the relationship between IEO dimensions and cyberpreneurial intentions. These personal traits amplify the impact of IEO on cyberpreneurial intentions by providing individuals with the skills and mindset necessary to translate their

entrepreneurial orientation into the digital context. Thus, we propose below hypotheses:

- H8: Psychological characteristics moderates the relationship between innovativeness and cyberpreneurship intentions.
- H9: Psychological characteristics moderates the relationship between risk-taking and cyberpreneurship intentions.
- H10: Psychological characteristics moderate the relationship between proactiveness and cyberpreneurship intentions.

By considering these hypotheses, the research framework proposed (refer to **Figure 1**). The proposed framework aims to provide a comprehensive understanding of the factors that drive university students' intentions to engage in cyberpreneurship within the context of digital free trade zones. Empirical testing of these relationships through quantitative analysis can contribute valuable insights to both academic research and practical policy considerations.

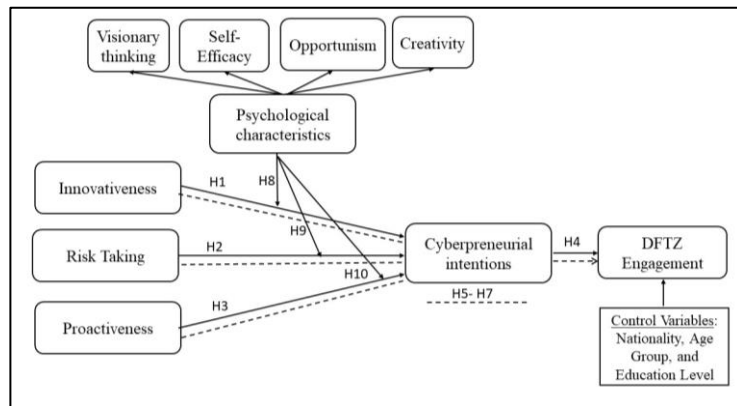

**Figure 1.** Research framework.

## 4. Methodology

### 4.1. Sample selection and data collection

In this study, quantitative research was conducted through the distribution of self-administered questionnaires. Final-year university students, the target population chosen for this study, are currently studying at public and private universities in Malaysia. The data were collected online through convenience, judgment, and quota sampling from 473 university students in Malaysia, regardless of their nationality. All questionnaires are usable and accepted for data analysis. Out of the 473 samples, 55% of them are male, and 45% are female. Besides, most respondents were aged between 18 and 24 years (54.5%), followed by 25 to 34 years (36.8%), while only 8.7% of the respondents were aged between 35 and 44 years. Approximately half of the respondents are in their undergraduate studies (50.5%), and 26% of the respondents are Diploma holders, whereas respondents from postgraduate studies have the lowest percentage (23.5%). There were more respondents from private universities (52.9%) than from public universities (47.1%).

## 4.2. Measurements

The questions are designed in the form of a five-point Likert scale from 1 “strongly disagree” to 5 “strongly agree”. A total of 3 items for cyberpreneurship were adapted from Wasowska (2019). Individual Entrepreneurial Orientation (IEO) is conceptualised by investigating the three dimensions, Innovativeness, Risk-taking, and Proactiveness. The questionnaire measured innovativeness (4 items), risk-taking (3 items) adapted from Langkamp Bolton and Lane (2012), and proactiveness (5 items). Psychological characteristics are conceptualised as second-order reflective constructs comprising visionary thinking, self-efficacy, opportunism, and creativity. Visionary thinking (5 items), opportunism (6 items), and creativity (6 items) adapted from Falahat et al. (2021); and self-efficacy (5 items) adapted from Fernandez-Perez et al. (2019). Cyberpreneurship is conceptualised as the intention to engage in online entrepreneurial activities. The concept of engagement in DFTZ is a response to the findings of Chin et al. (2023) study that 40% of the target respondents were pessimistic about DFTZ and did not comprehend the potential benefits beyond it. This study aims to examine the factors that can enhance engagement in DFTZ and utilise the benefits they offer.

## 4.3. Data analysis

The partial least square structural equation modeling (PLS-SEM) technique via SmartPLS version 4.0 has been employed for data analysis. We assessed the measurement model for internal consistency and convergent validity. Composite reliability and average variance extracted (AVE) values are presented in **Table 1** and show the values with the recommended threshold limit. The cut-off value used for composite reliability is 0.70, and the cut-off value for AVE is 0.50 (Hair et al. 2021). Following Henseler et al. (2014), the measurement models were checked for discriminant validity using the heterotrait-monotrait (HTMT) approach, and the cut-off value was set to 0.90.

**Table 1.** Measurement model assessment.

Constructs	Items	Loadings	Cronbach's alpha	CR	AVE
Innovativeness	A1	0.86	0.86	0.9	0.7
	A2	0.87	-	-	-
	A3	0.84	-	-	-
	A4	0.78	-	-	-
Risk taker	B1	0.91	0.88	0.93	0.81
	B2	0.88	-	-	-
	B3	0.91	-	-	-
Proactiveness	C1	0.84	0.87	0.91	0.66
	C2	0.86	-	-	-
	C3	0.85	-	-	-
	C4	0.73	-	-	-
	C5	0.79	-	-	-

**Table 1.** (Continued).

Constructs	Items	Loadings	Cronbach's alpha	CR	AVE
Visionary thinking	D1	0.77	0.85	0.9	0.63
	D2	0.84	-	-	-
	D3	0.76	-	-	-
	D4	0.81	-	-	-
	D5	0.79	-	-	-
Self-Efficacy	E1	0.85	0.92	0.94	0.75
	E2	0.87	-	-	-
	E3	0.88	-	-	-
	E4	0.86	-	-	-
	E5	0.87	-	-	-
Opportunism	F1	0.83	0.89	0.92	0.66
	F2	0.85	-	-	-
	F3	0.81	-	-	-
	F4	0.81	-	-	-
	F5	0.77	-	-	-
	F6	0.79	-	-	-
Creativity	G1	0.84	0.88	0.91	0.63
	G2	0.87	-	-	-
	G3	0.8	-	-	-
	G4	0.78	-	-	-
	G5	0.7	-	-	-
	G6	0.77	-	-	-
Cyberpreneurial intentions	I1	0.93	0.94	0.96	0.89
	I2	0.95	-	-	-
	I3	0.95	-	-	-
DFTZ engagement	J1	0.82	0.93	0.94	0.66
	J2	0.81	-	-	-
	J3	0.82	-	-	-
	J4	0.83	-	-	-
	J5	0.84	-	-	-
	J6	0.77	-	-	-
	J7	0.77	-	-	-
	J8	0.83	-	-	-

Note: Composite reliability (CR), average variance extracted (AVE).

#### 4.4. Common method bias (CMB)

We have examined the CMB by testing full collinearity (Kock, 2015), the occurrence of VIF greater than 3.3 suggests that CMB is not a concern in this study. In addition to the full collinearity test, we used a marker variable approach to look at other possible existing bias. The marker variable approach (Lindell & Whitney, 2001) provides a correction factor through the use of a marker variable (one theoretically

unrelated to other items in the survey) of the same scale type. The results of both methods—the full collinearity test and the marker variable approach—reconfirm that these methods collectively indicate that CMB is not a concern in this study.

## 5. Results and findings

### 5.1. Measurement model assessment

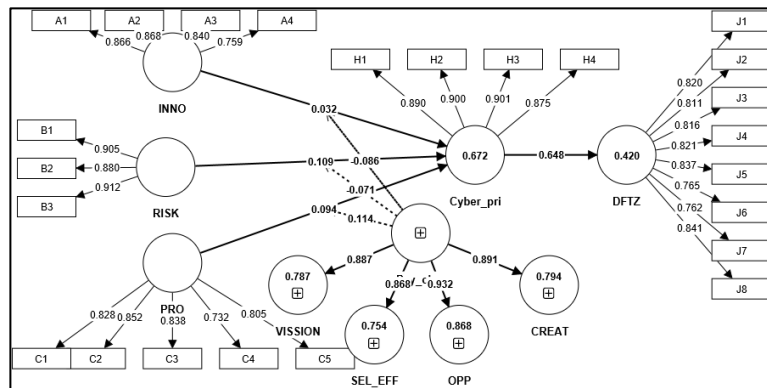

Figure 2. Measurement model.

With reference to **Figures 2 and 3**, the measurement and structural models are presented. The factor loadings, Cronbach’s alpha, composite reliability, and convergent validity from the measurement models are presented in **Table 1**. The reliability of the indicator is confirmed through the loading values, which show that the values of all items are greater than the threshold of 0.7. For all constructs in the model, the Cronbach alpha coefficients are greater than the acceptable value of 0.7, varying from 0.85 to 0.94. Composite reliability has also been assessed as an alternate measure of internal consistency reliability (Hair et al., 2021). The composite reliability values of the construct exceeded 0.7, indicating a sufficient level of reliability with acceptable values. Besides, AVE serves as a measure of convergent validity, in which items shown in the table are above 0.5, indicating acceptance, demonstrating that the explanatory power of the constructs toward the indicators is satisfactory (Hair et al., 2019; Hair et al., 2021).

The results shown in **Table 2** are the values of Heterotrait-Monotrait (HTMT) for evaluating the discriminant validity of the model. According to Henseler et al. (2014), discriminant validity is formed by applying acceptable values of either 0.85 or 0.9. The majority of values presented in **Table 2** are below 0.9, which refers to acceptable discriminant validity, while values exceeding 0.90 suggest an insufficient level of discriminant validity.

Table 2. Discriminant validity (HTMT).

Constructs	Create	Cyber_pri	DFTZ	INNO	OPP	PRO	RISK	Sel_eff
Cyber_pri	0.786	-	-	-	-	-	-	-
DFTZ	0.655	0.703	-	-	-	-	-	-
INNO	0.716	0.757	0.665	-	-	-	-	-
OPP	0.897	0.827	0.652	0.789	-	-	-	-

**Table 2.** (Continued).

Constructs	Create	Cyber_pri	DFTZ	INNO	OPP	PRO	RISK	Sel_eff
PRO	0.795	0.79	0.669	0.864	0.856	-	-	-
RISK	0.682	0.723	0.643	0.852	0.717	0.778	-	-
Sel_eff	0.707	0.777	0.634	0.757	0.805	0.818	0.74	-
VISSION	0.812	0.789	0.647	0.812	0.866	0.908	0.746	0.835

Note: HTMT Value < 0.90.

**5.2. Structural model assessment and hypothesis testing results**

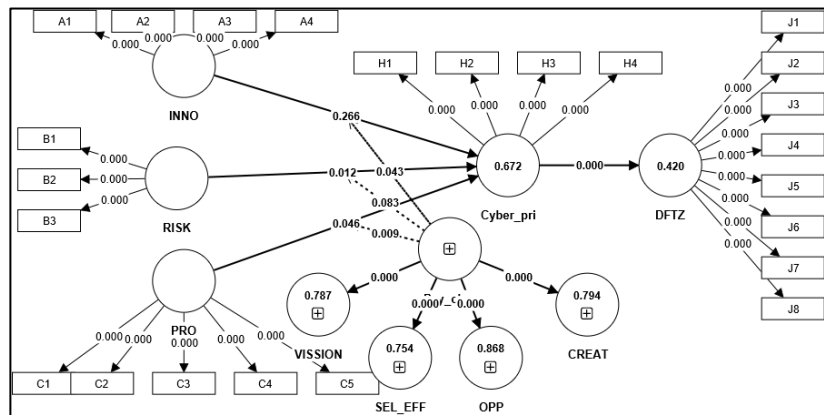

**Figure 3.** Structural model.

**6. Discussion**

**6.1. Impact of IEO dimensions on cyberpreneurship**

The first objective of this study was to examine the impact of international Entrepreneurial Orientation (IEO) dimensions—innovativeness, risk-taking, and proactiveness—on cyberpreneurship among university students. Our findings, derived from partial least square structural equation modeling (PLS-SEM), reveal a nuanced understanding of these relationships.

Contrary to our first hypothesis (H1) and existing literature (e.g., Mir et al., 2022; Wathanakom et al., 2020; Dutta et al., 2015; Pearson and Pearson, 2008), we found no significant impact of innovativeness on cyberpreneurship intentions. This unexpected result suggests that while innovativeness is a critical trait for entrepreneurial success, its role in stimulating cyberpreneurship intentions among university students may be contingent upon additional factors, such as the learning environment and institutional support, as suggested by Mir et al. (2022).

Conversely, our hypotheses regarding risk-taking (H2) and proactiveness (H3) were supported, aligning with findings from recent studies (e.g., Tommy et al., 2021; Juan et al., 2022; Zhao and Smallbone, 2019; Bjekić et al., 2023). These results underscore the importance of these traits in fostering entrepreneurial intentions, specifically in the context of cyberpreneurship.

### 6.2. Cyberpreneurship and DFTZ engagement

The second part of our discussion addresses the relationship between cyberpreneurship and engagement in the Digital Free Trade Zone (DFTZ). Our results affirm the hypothesis (H4) that cyberpreneurship positively influences DFTZ engagement. Although no direct precedent in literature was found, our findings resonate with the broader narrative of digital technologies' role in entrepreneurial orientation, as discussed by Fellnhofer (2022). This suggests that digital platforms, like those in the DFTZ, can act as catalysts for entrepreneurial activities.

Additionally, our study reveals that risk-taking (RISK) and proactiveness (PRO) are significant contributors to cyberpreneurship intentions, which, in turn, are likely to enhance DFTZ engagement. This finding adds a new dimension to our understanding of how specific entrepreneurial traits can influence engagement in digital trade platforms.

### 6.3. Moderating role of psychological characteristics

The third aspect of our discussion focuses on the moderating role of psychological characteristics in the relationship between IEO dimensions and cyberpreneurship intentions. Our analysis, as reflected in **Table 3**, indicates that psychological traits namely visionary thinking, self-efficacy, opportunism, and creativity significantly moderate this relationship. These findings (H8, H9, and H10) highlight the pivotal role of psychological characteristics in enhancing the impact of entrepreneurial traits on cyberpreneurship intentions.

**Table 3.** Hypotheses testing.

Hypothesis	Descriptions	Std_Beta	Std_Error	T_values	P_values	Decisions
H1	INNO » Cyber_pri	0.032	0.051	0.625	0.266	Not Supported
H2	RISK » Cyber_pri	0.109	0.048	2.266	0.012**	Supported
H3	PRO » Cyber_pri	0.094	0.056	1.684	0.046**	Supported
H4	Cyber_pri » DFTZ	0.648	0.031	20.886	0***	Supported
H5	INNO » Cyber_pri » DFTZ	0.021	0.034	0.619	0.268	Not Supported
H6	RISK » Cyber_pri » DFTZ	0.071	0.032	2.233	0.013**	Supported
H7	PRO » Cyber_pri » DFTZ	0.061	0.036	1.682	0.047**	Supported
H8	Psy_char × INNO » Cyber_pri	-0.086	0.05	1.715	0.043**	Supported
H9	Psy_char × RISK » Cyber_pri	-0.071	0.051	1.388	0.083*	Supported
H10	Psy_char × PRO » Cyber_pri	0.114	0.048	2.376	0.009***	Supported

Note: P-value < 0.10\*, <0.05\*\*, <0.0.

Interestingly, the incorporation of these psychological characteristics appears to compensate for the lack of direct impact of innovativeness on cyberpreneurship intentions. This suggests that fostering these psychological traits in students is crucial for realizing the full potential of their entrepreneurial orientation, particularly in the context of engaging with digital platforms like the DFTZ.

Interestingly, the incorporation of these psychological characteristics appears to compensate for the lack of direct impact of innovativeness on cyberpreneurship intentions. This suggests that fostering these psychological traits in students is crucial for realizing the full potential of their entrepreneurial orientation, particularly in the context of engaging with digital platforms like the DFTZ.

## **7. Conclusions**

In conclusion, this study delved into the intricate relationship between IEO and cyberpreneurship intentions within the context of Digital Free Trade Zones (DFTZ) in Malaysia. The empirical findings presented a nuanced understanding of the factors that influence university students' intentions to engage in cyberpreneurship and the subsequent impact on their participation in DFTZ. The discussion of these findings sheds light on several noteworthy points. The examination of the dimensions of IEO revealed that while innovativeness did not demonstrate a direct effect on cyberpreneurship intentions, risk-taking, and proactiveness exhibited significant positive impacts. These results align with existing research highlighting the pivotal roles of risk-taking and proactiveness in fostering entrepreneurial intentions. The discrepancy in the effect of innovativeness underscores the need for a conducive learning environment to nurture and harness this trait effectively, potentially through targeted educational initiatives.

Furthermore, the identification of a positive relationship between cyberpreneurship and DFTZ engagement introduces a novel insight into the evolving landscape of digital trade. The influence of digital technologies on entrepreneurial orientation, as discussed by Fellnhofner (2022), substantiates the notion that digital platforms, such as those within DFTZ, can stimulate diverse stakeholders to explore opportunities and engage with the platform ecosystem. The findings also highlight the influential roles of risk-taking and proactiveness in driving both cyberpreneurship intentions and subsequent involvement in DFTZ.

Importantly, the analysis of psychological characteristics as moderators in the relationship between IEO dimensions and cyberpreneurship intentions unveils the pivotal role of visionary thinking, self-efficacy, opportunism, and creativity. These psychological traits significantly moderate the link between entrepreneurial orientation and intentions, emphasizing their vital role in shaping intentions and promoting engagement with DFTZ platforms. The implication is clear: fostering and developing these psychological characteristics among university students can enhance their propensity for cyberpreneurship and engagement in digital trade initiatives.

## **8. Implications**

Overall, this study significantly contributes to the growing body of literature on entrepreneurial behavior within the context of digital economies. The empirical findings provide actionable insights for policymakers, educators, and entrepreneurs aiming to foster a conducive ecosystem for cyberpreneurship and digital trade engagement. As Malaysia and similar economies continue their journey toward digital transformation, understanding the complex interplay between individual orientation,



psychological traits, and digital platforms becomes imperative for harnessing the full potential of cyberpreneurship and its impact on economic growth.

In light of these conclusions, this research urges educators to prioritize the development of psychological characteristics alongside entrepreneurial traits within their curricula. Policymakers should consider tailoring interventions to encourage risk-taking and proactiveness among aspiring entrepreneurs while fostering a culture of innovation. Entrepreneurs and stakeholders can leverage the insights from this study to strategize their involvement in digital trade initiatives, capitalizing on the symbiotic relationship between entrepreneurial orientation and digital platform engagement.

In summary, the Influence of Individual Entrepreneurial Orientation on Cyberpreneurship within the context of Digital Free Trade Zones is a multi-faceted phenomenon with implications that span education, policy, and practice. This study illuminates a path forward for nurturing digital entrepreneurs and harnessing the transformative power of digital trade in the global economy.

**Author contributions:** Conceptualization, MF; methodology, AGS; validation, KMN, AGS and NAMZ; formal analysis, MF; writing—original draft preparation, MF; writing—review and editing, KMN, AGS and NAMZ; visualization, AGS; funding acquisition, MF; KMN, AGS and NAMZ. All authors have read and agreed to the published version of the manuscript.

**Acknowledgments:** The authors would like to express their sincere gratitude to the Asia Pacific University of Technology and Innovation (APU) for their generous sponsorship of the Article Processing Charges (APC) associated with the publication of this paper. This support has been instrumental in enabling the dissemination of our research findings to a wider audience. We deeply appreciate the Asia Pacific University of Technology and Innovation (APU)'s commitment to fostering academic and scientific research.

**Conflict of interest:** The authors declare no conflict of interest.

## References

- Alam, S. S., Mohd, R., Kamaruddin, B. H., & Nor, N. G. M. (2015). Personal values and entrepreneurial orientations in Malay entrepreneurs in Malaysia. *International Journal of Commerce and Management*, 25(4), 385–401. <https://doi.org/10.1108/ijcoma-01-2013-0001>
- Ajzen, I. (1991). The theory of planned behavior. *Organizational Behavior and Human Decision Processes*, 50(2), 179–211. [https://doi.org/10.1016/0749-5978\(91\)90020-t](https://doi.org/10.1016/0749-5978(91)90020-t)
- Aloulou, W.J. (2023). Predicting entrepreneurial intentions of final year Saudi university business students by applying the theory of planned behavior. *Journal of Small Business and Enterprise Development*, 23(4), 1142–1164
- Anderson, J. R. (2023). The role of subjective norms in developing entrepreneurial intentions in university students. *Journal of Strategy and Management*, 16(4), 643–653. <https://doi.org/10.1108/jsma-10-2022-0190>
- Audretsch, D., & Keilbach, M. (2004). Entrepreneurship Capital and Economic Performance. *Regional Studies*, 38(8), 949–959. <https://doi.org/10.1080/0034340042000280956>
- Bateman, T. S., & Crant, J. M. (1993). The proactive component of organizational behavior: A measure and correlates. *Journal of Organizational Behavior*, 14(2), 103–118. Portico. <https://doi.org/10.1002/job.4030140202>
- Bjekić, D., Zlatić, L., & Zlatković, B. (2023). Entrepreneurial orientation of the female students of educational professions. *Inovacije u Nastavi*, 36(1), 70–85. <https://doi.org/10.5937/inovacije2301070b>

- Bolton, D.L. and Lane, M.D. (2012). Individual entrepreneurial orientation: development of a measurement instrument, *Education and Training*, 54 (2–3), 219–233.
- Chesbrough, H. (2002). The role of the business model in capturing value from innovation: Evidence from Xerox Corporation's technology spin-off companies. *Industrial and Corporate Change*, 11(3), 529–555. <https://doi.org/10.1093/icc/11.3.529>
- Chin, M. Y., Foo, L. P., & Falahat, M. (2023). Digital Free Trade Zone in Facilitating Small Medium Enterprises for Globalisation: A Perspective from Malaysia Small and Medium Enterprises. *Business and Economic Research*, 13(2), 40. <https://doi.org/10.5296/ber.v13i2.20835>
- Covin, J. G., Rigtering, J. P. C., Hughes, M., Kraus, S., Cheng, C.-F., & Bouncken, R. B. (2020). Individual and team entrepreneurial orientation: Scale development and configurations for success. *Journal of Business Research*, 112, 1–12. <https://doi.org/10.1016/j.jbusres.2020.02.023>
- Davidsson, P. (2004). *Researching Entrepreneurship*. Springer, New York.
- Davis, M. H., Hall, J. A., & Mayer, P. S. (2016). Developing a new measure of entrepreneurial mindset: Reliability, validity, and implications for practitioners. *Consulting Psychology Journal: Practice and Research*, 68(1), 21–48. <https://doi.org/10.1037/cpb0000045>
- Durac, L., & Moga, L.M. (2023). Applications of Decomposed Theory of Planned Behaviour in Making Decision to Adopt a Career in Social Entrepreneurship. *European Journal of Interdisciplinary Studies*, 15(1), 16–30.
- Elali, W., & Al-Yacoub, B. (2016). Factors affecting entrepreneurial intentions among Kuwaitis. *World Journal of Entrepreneurship, Management and Sustainable Development*, 12(1), 18–34. <https://doi.org/10.1108/wjemsd-07-2015-0029>
- Falahat, M., Ling, T. J., & Thurasamy, R. (2021). The impact of psychological characteristics and COVID-19 on entrepreneurial intention in Malaysia. *J. for Global Business Advancement*, 14(5), 662. <https://doi.org/10.1504/jgba.2021.123557>
- Fayolle, A., & Liñán, F. (2014). The future of research on entrepreneurial intentions. *Journal of Business Research*, 67(5), 663–666. <https://doi.org/10.1016/j.jbusres.2013.11.024>
- Fellnhöfer, K. (2022). Entrepreneurial alertness toward responsible research and innovation: Digital technology makes the psychological heart of entrepreneurship pound. *Technovation*, 118, 102384. <https://doi.org/10.1016/j.technovation.2021.102384>
- Fernández-Pérez, V., Montes-Merino, A., Rodríguez-Ariza, L., & Galicia, P. E. A. (2017). Emotional competencies and cognitive antecedents in shaping student's entrepreneurial intention: The moderating role of entrepreneurship education. *International Entrepreneurship and Management Journal*, 15(1), 281–305. <https://doi.org/10.1007/s11365-017-0438-7>
- Gurol, Y., & Atsan, N. (2006). Entrepreneurial characteristics amongst university students: Some insights for entrepreneurship education and training in Turkey. *Education and Training*, 48 (1), 25–38.
- Hair, J. F., Hult, G. T. M., Ringle, C. M., Sarstedt, M., Danks, N. P., & Ray, S. (2021). *Partial Least Squares Structural Equation Modeling (PLS-SEM) Using R*. In *Classroom Companion: Business*. Springer International Publishing. <https://doi.org/10.1007/978-3-030-80519-7>
- Hair, J. F., Risher, J. J., Sarstedt, M., & Ringle, C. M. (2019). When to use and how to report the results of PLS-SEM. *European Business Review*, 31(1), 2–24. <https://doi.org/10.1108/eb-11-2018-0203>
- Hasbolah, Mamat, Abdullah, & Sidek. (2020). A Review on Cyber Entrepreneurship in Malaysia: Past, Present and Future. *Journal of Critical Reviews*, 7(14), 2628–2636. <https://doi.org/10.31838/jcr.07.19.513>
- Henseler, J., Ringle, C. M., & Sarstedt, M. (2014). A new criterion for assessing discriminant validity in variance-based structural equation modeling. *Journal of the Academy of Marketing Science*, 43(1), 115–135. <https://doi.org/10.1007/s11747-014-0403-8>
- Hernández-Perlines, F., Ibarra Cisneros, M. A., Ribeiro-Soriano, D., & Mogorrrón-Guerrero, H. (2019). Innovativeness as a determinant of entrepreneurial orientation: analysis of the hotel sector. *Economic Research-Ekonomska Istraživanja*, 33(1), 2305–2321. <https://doi.org/10.1080/1331677x.2019.1696696>
- Jiao, H., Wang, L., & Shi, Y. (2022). How does institutional environment in the digital context affect technology entrepreneurship? The moderating roles of government digitalization and gender. *Journal of Organizational Change Management*, 35(7), 1089–1112. <https://doi.org/10.1108/jocm-10-2021-0321>
- Jin, B., Jung, S., & Jeong, S. W. (2017). Dimensional effects of Korean SME's entrepreneurial orientation on internationalization and performance: The mediating role of marketing capability. *International Entrepreneurship and Management Journal*, 14(1), 195–215. <https://doi.org/10.1007/s11365-017-0457-4>

- Kock, N. (2015). Common Method Bias in PLS-SEM. *International Journal of E-Collaboration*, 11(4), 1–10. <https://doi.org/10.4018/ijec.2015100101>
- Koh, H. C. (1996). Testing hypotheses of entrepreneurial characteristics: A study of Hong Kong MBA students. *Journal of Managerial Psychology*, 11(3), 12–25. <https://doi.org/10.1108/02683949610113566>
- Kropp, F., Lindsay, N. J., & Shoham, A. (2008). Entrepreneurial orientation and international entrepreneurial business venture startup. *International Journal of Entrepreneurial Behavior & Research*, 14(2), 102–117. <https://doi.org/10.1108/13552550810863080>
- Kusmintarti, A., Thoyib, A., Maskie, G., & Ashar, K. (2016). Entrepreneurial Characteristics as a Mediation of Entrepreneurial Education Influence on Entrepreneurial Intention. *Journal of Entrepreneurship Education*, 19, 24.
- Langkamp Bolton, D., & Lane, M. D. (2012, April 13). Individual entrepreneurial orientation: Development of a measurement instrument. *Education + Training*, 54(2/3), 219–233. <https://doi.org/10.1108/00400911211210314>
- Lee, K. W., Tsai, M. T., & Lanting, M. C. L. (2011, January). From marketplace to marketspace: Investigating the consumer switch to online banking. *Electronic Commerce Research and Applications*, 10(1), 115–125. <https://doi.org/10.1016/j.elerap.2010.08.005>
- Lee, S. M., & Peterson, S. J. (2000). Culture, entrepreneurial orientation, and global competitiveness. *Journal of World Business*, 35(4), 401–416. [https://doi.org/10.1016/s1090-9516\(00\)00045-6](https://doi.org/10.1016/s1090-9516(00)00045-6)
- Liñán, F. (2008). Skill and value perceptions: How do they affect entrepreneurial intentions? *International Entrepreneurship and Management Journal*, 4(3), 257–272. <https://doi.org/10.1007/s11365-008-0093-0>
- Lindell, M. K., & Whitney, D. J. (2001). Accounting for common method variance in cross-sectional research designs. *Journal of Applied Psychology*, 86(1), 114–121. <https://doi.org/10.1037/0021-9010.86.1.114>
- Linton, G. (2019). Innovativeness, risk-taking, and proactiveness in startups: A case study and conceptual development. *Journal of Global Entrepreneurship Research*, 9(1). <https://doi.org/10.1186/s40497-019-0147-5>
- Lumpkin, G. T., & Dess, G. G. (1996). Clarifying the Entrepreneurial Orientation Construct and Linking It to Performance. *The Academy of Management Review*, 21(1), 135. <https://doi.org/10.2307/258632>
- Martins, I., & Perez, J. P. (2020). Testing mediating effects of individual entrepreneurial orientation on the relation between close environmental factors and entrepreneurial intention. *International Journal of Entrepreneurial Behavior & Research*, 26(4), 771–791. <https://doi.org/10.1108/ijeb-08-2019-0505>
- Mir, A. A., Hassan, S., & Khan, S. J. (2022). Understanding digital entrepreneurial intentions: A capital theory perspective. *International Journal of Emerging Markets*, 18(12), 6165–6191. <https://doi.org/10.1108/ijem-05-2021-0687>
- Ngoc Khuong, M., & Huu An, N. (2016). The Factors Affecting Entrepreneurial Intention of the Students of Vietnam National University—A Mediation Analysis of Perception toward Entrepreneurship. *Journal of Economics, Business and Management*, 4(2), 104–111. <https://doi.org/10.7763/joebm.2016.v4.375>
- Nikitina, T., Licznarska, M., Ozoliņa-Ozola, I., & Lapina, I. (2022). Individual entrepreneurial orientation: Comparison of business and STEM students. *Education + Training*, 65(4), 565–586. <https://doi.org/10.1108/et-07-2021-0256>
- Park, C. (2017). A study on effect of entrepreneurship on entrepreneurial intention. *Asia Pacific Journal of Innovation and Entrepreneurship*, 11(2), 159–170. <https://doi.org/10.1108/apjie-08-2017-024>
- Parveen, F., Jaafar, N. I., & Ainin, S. (2015). Social media usage and organizational performance: Reflections of Malaysian social media managers. *Telematics and Informatics*, 32(1), 67–78. <https://doi.org/10.1016/j.tele.2014.03.001>
- Pearson, J.M. & Pearson, A.M. (2008). An Exploratory Study into Determining the Relative Importance of Key Criteria in Web Usability: A Multi-Criteria Approach. *Journal of Computer Information Systems*, 48:4, 115–127, DOI: 10.1080/08874417.2008.11646041
- Perez, J. P., Martins, I., Mahauad, M. D., & Sarango-Lalangui, P. O. (2022). A bridge between entrepreneurship education, program inspiration, and entrepreneurial intention: The role of individual entrepreneurial orientation. Evidence from Latin American emerging economies. *Journal of Entrepreneurship in Emerging Economies*. <https://doi.org/10.1108/jeee-04-2021-0137>
- Preller, R., Patzelt, H., & Breugst, N. (2020). Entrepreneurial visions in founding teams: Conceptualization, emergence, and effects on opportunity development. *Journal of Business Venturing*, 35(2), 105914. <https://doi.org/10.1016/j.jbusvent.2018.11.004>
- Renko, M., Kroeck, K. G., & Bullough, A. (2012). Expectancy theory and nascent entrepreneurship. *Small Business Economics*, 39(3), 667–684. <https://doi.org/10.1007/s11187-011-9354-3>

- Sabah, S. (2016). Entrepreneurial Intention: Theory of Planned Behaviour and the Moderation Effect of Start-Up Experience. *Entrepreneurship—Practice-Oriented Perspectives*. <https://doi.org/10.5772/65640>
- Santos, G., Marques, C. S., & Ferreira, J. J. M. (2020). Passion and perseverance as two new dimensions of an Individual Entrepreneurial Orientation scale. *Journal of Business Research*, 112, 190–199. <https://doi.org/10.1016/j.jbusres.2020.03.016>
- Shane, S., & Venkataraman, S. (2000). The Promise of Entrepreneurship as a Field of Research. *The Academy of Management Review*, 25(1), 217. <https://doi.org/10.2307/259271>
- Shepherd, D. A. (2016). Decision Making in Entrepreneurship. <https://doi.org/10.4337/9781784716042>
- Tommy, Wirawan, & Junko. (2021). The dynamics of individual entrepreneurial orientation in the relationship between entrepreneurship education and entrepreneurial intention. *Journal of Applied Management (JAM)*, 19(3), 688–702.
- Tsai, F.S. and Hsu, I.C. (2019). The effects of social capital on knowledge heterogeneity. *Management Decision*, 57(5), 1237–1253. <https://doi.org/10.1108/md-12-2016-0909>
- Urbano, D., Guerrero, M., Ferreira, J. J., & Fernandes, C. I. (2019). New technology entrepreneurship initiatives: Which strategic orientations and environmental conditions matter in the new socio-economic landscape? *The Journal of Technology Transfer*, 44(5), 1577–1602. <https://doi.org/10.1007/s10961-018-9675-3>
- Wang, C. L., & Altinay, L. (2012). Social embeddedness, entrepreneurial orientation and firm growth in ethnic minority small businesses in the UK. *International Small Business Journal: Researching Entrepreneurship*, 30(1), 3–23. <https://doi.org/10.1177/0266242610366060>
- Wasowska, A. (2019). Social-cognitive antecedents of new venture internationalization. *Baltic Journal of Management*, 14(3), 462–479. <https://doi.org/10.1108/bjm-09-2018-0325>
- Wathanakom, N., Khlaisang, J., & Songkram, N. (2020). The study of the causal relationship between innovativeness and entrepreneurial intention among undergraduate students. *Journal of Innovation and Entrepreneurship*, 9(1). <https://doi.org/10.1186/s13731-020-00125-5>
- Zhao, D., & Smallbone, D. (2019). What affects nascent entrepreneurs' proactiveness. *Asia Pacific Management Review*, 24(4), 318–326. <https://doi.org/10.1016/j.apmr.2018.12.001>