

ORIGINAL RESEARCH ARTICLE

Wolfram Mathematica, exact solutions for heat transfer methods applied to extrusion processes

Antonio-Jiménez Ramos^{1*}, Juan Francisco-Puertas Fernández², Margarita J.-Lapido Rodríguez³, Julio Rafael-Gómez Sarduy³, Yulier-Jiménez Santana⁴, Fidel-Sosa Núñez⁴

¹ Empresa de Producciones Plásticas Vasil Levski, Cuba. E-mail: antonio@petrocasa.minem.cu

² Departamento Mecánica, Facultad de Ingeniería, Universidad de Cienfuegos, Cuba.

³ Centro de Estudio de Energía y Medio Ambiente (CEEMA), Facultad de Ingeniería, Universidad de Cienfuegos, Cuba.

⁴ Universidad de Guanajuato, México.

ABSTRACT

Computer programs for the solution of everyday problems are very common because of the speed with which results can be obtained, which by traditional methods would be very laborious and especially those in which the solutions take repeated calculations. The work intends to demonstrate how, through programming, applying the exact solution method, fast and precise results can be obtained on similarities and differences between different geometries in heat transfer, which demonstrate the behavior, according to parameters, under equal conditions (geometric properties, diameters, lengths, thicknesses, volumes) and physical properties (thermal conductivity, specific heat and density), appreciating how they influence results such as cooling times, production according to the physical properties and design of the equipment, consumption rates, core and surface temperatures and others, according to the plastic pipe extrusion method, necessary in production processes that require constant monitoring.

Keywords: Extrusion Processes; Simple Geometries; Modeling; Physical Properties; Heat Transfer; Wolfram Mathematica Software

ARTICLE INFO

Received: 8 February 2021
Accepted: 12 March 2021
Available online: 29 March 2021

COPYRIGHT

Copyright © 2021 Antonio-Jiménez Ramos, et al.
EnPress Publisher LLC. This work is licensed under the Creative Commons Attribution-NonCommercial 4.0 International License (CC BY-NC 4.0).
<https://creativecommons.org/licenses/by-nc/4.0/>

1. Introduction

Wolfram Mathematica, by its very nature, is used in the scientific areas of engineering in its various mathematical and computational specialties. Commonly considered a computer algebra system, Mathematica is also a powerful tool for general-purpose programming. Hence, it can be used for multiple solutions to engineering problems^[1-3], being a language that is constantly updated, always with greater application possibilities.

Generally, the solution to heat transfer problems in pipes and plates in the extrusion technology are performed by the first term approximation method, taking into account the ease of calculation, especially for problems where a high accuracy is not required, being able to reach with it up to 96%–98%, approximately, making it very complex to reach higher accuracies without using the exact solution method.

The exact solution method requires numerical analysis for its solution due to the complexity of its equations, hence the use of different software. In this case, the solution with Wolfram Mathematica 8.0 always starts from the conformation of the equations that represent

each of these geometries, for the case of plates, Cartesian coordinates, and for pipes, cylindrical coordinates, which must be meticulously developed to obtain the desired results, since the solution for each of them have similarities^[4-6].

The work aims to demonstrate, the feasibility of using this software, to achieve fast results and with the pressures that are required, for each of the particularities that are presented, being able to be a way of comparison of parameters, such as the energy behavior of different geometries. In this case, plates and pipes, in volumes, taking into account similar parameters and raw materials, in terms of production, consumption rates, cooling times, external and internal temperatures and others^[7-9].

2. Materials and methods

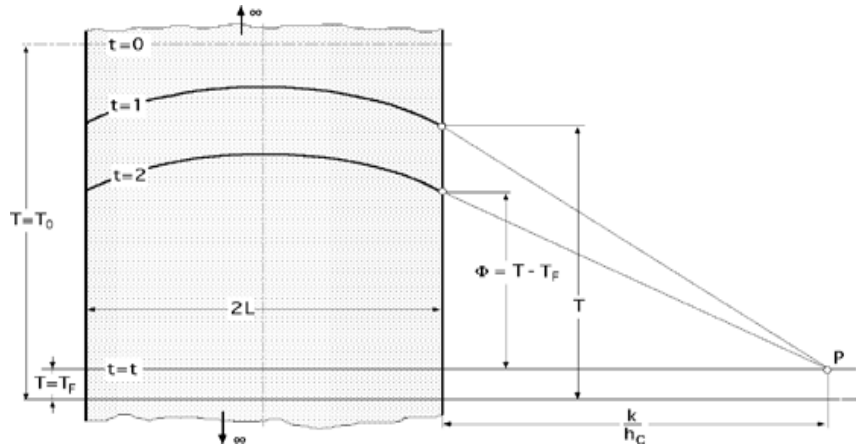

Figure 1. Interpretation of the convection boundary condition on an infinite plate.

$$\alpha \frac{\partial^2 T}{\partial x^2} = \frac{\partial T}{\partial t}, \text{ with } T = (x, t) \quad (1)$$

By changing the variable $\Phi = T - T_f$ with $T_f \neq 0$; equation (2):

$$\alpha \frac{\partial^2 \Phi}{\partial x^2} = \frac{\partial \Phi}{\partial t} \quad (2)$$

Whose general solution is equation (3):

$$\Phi = \lambda e^{-\lambda^2 \alpha t} [B_1 \text{Sen}(\lambda x) - B_2 \text{Cos}(\lambda x)] \quad (3)$$

For $T = 0$, $-L \leq X \leq L$; $\Phi = f(x)$ or $T_0/2$ for $T > 0$ it will be satisfied; equation (4):

$$x = 0: \left(\frac{\partial \Phi}{\partial x} \right)_{x=0} = 0, \quad x = \pm L$$

In heat transfer, there are many ways to solve problems used in engineering, in this first case, the solution for programming in Wolfram Mathematica 8.0, corresponds to a plate, surrounded by a convecting fluid, at the final temperature T_f , which is instantly introduced into the fluid under conditions where the resistance to heat transfer is very small, see in **Figure 1**. By the concept of plate and that the fluid is the same and is on both sides, there is symmetry and it turns out that the convective coefficient h_c , will be the same between both half-plates, so that, considering this infinite plate of thickness (esp. = $2L$) for which at time ($t = 0$), there is a known temperature distribution and in which there are no edge effects, the differential equation^[1,10,11], equation (1), applies.

$$-k \left(\frac{\partial \Phi}{\partial x} \right)_{x=\pm L} = h_c \Phi$$

$$\left(\frac{\partial \Phi}{\partial x} \right)_{x=\pm L} = -\frac{h_c}{k} \Phi = a_1 \Phi \quad (4)$$

As the fluid on both sides of the plate is the same, then $\Phi_{-x} = \Phi_{+x}$, $h_c/k = Cte = -a_1$ and the equality is satisfied for any value of Φ .

Taking into account the boundary condition $x = 0$; equation (5):

$$\left(\frac{\partial \Phi}{\partial x} \right)_{x=0} = 0 = \lambda e^{-\lambda^2 \alpha t} [B_1 \text{Cos}(\lambda x) - B_2 \text{Sen}(\lambda x)]_{x=0} \Rightarrow B_1 = 0 \quad (5)$$

The solution reduces to equation (6):

$$\phi = Be^{-\lambda^2 \alpha t} \text{Cos}(\lambda x) \quad (6)$$

The boundary condition at $(x = \pm L)$ allows to obtain the values of λ ; equation (7):

$$\begin{aligned} \left(\frac{\partial \phi}{\partial x}\right)_{x=\pm L} &= -\frac{hc}{k} \phi \Rightarrow B\lambda e^{-\lambda^2 \alpha t} [-\text{Sen}(\lambda x)]_{x=L} \\ &= -\frac{hc}{k} [Be^{-\lambda^2 \alpha t} \text{Cos}(\lambda x)]_{x=L} \\ \text{Sen}(\lambda L) &= \frac{hc}{k\lambda} \text{Cos}(\lambda L); \text{Cot}g(\lambda L) = \frac{\lambda L}{Bi} \end{aligned} \quad (7)$$

This equation is satisfied for an infinite number of values of the parameter (λL) , so that for a given value of L , its solutions are found for various values of λ , intersecting at the curves: equation (8),

$$y = \text{Cot}g(\lambda L); y = \frac{\lambda L}{Bi} \quad (8)$$

Note the dependence of the equation on Bi .

Therefore, the temperature distribution is a series of the form; equation (9):

$$\frac{\phi}{\phi_0} = \frac{T_c - T_f}{T_0 - T_f} = 2 \sum_{n=1}^{\infty} \lambda_n e^{-\lambda_n^2 \alpha t} \frac{\text{Sen}(\lambda_n L) \text{Cos}(\lambda_n x)}{\lambda_n L + \text{Sen}(\lambda_n L) \text{Cos}(\lambda_n L)} \quad (9)$$

In which λ_n is the n th root of the equation; equation (10):

$$\text{Cot}g(\lambda_n L) = \frac{\lambda_n L}{Bi} \quad (10)$$

The initial condition $\Phi = f(x) = \Phi_0 = Cte$, for $(t = 0)$; equation (11):

$$f(x) = \sum_{n=1}^{\infty} B_n \text{Cos}(\lambda_n L) \quad (11)$$

From which B_n is obtained, taking into account the theory of orthogonal functions.

The expression of the temperature distribution, on the infinite plate, as a function of position and time; equation (12):

$$\begin{aligned} \phi &= 2 \sum_{n=1}^{\infty} \lambda_n e^{-\lambda_n^2 \alpha t} \frac{\text{Cos}(\lambda_n x)}{\lambda_n L + \text{Sen}(\lambda_n L) \text{Cos}(\lambda_n L)} \\ &\int_0^L f(x) \text{Cos}(\lambda_n x) dx \end{aligned} \quad (12)$$

For the particular case, in which the first boundary condition would be of the form.

$\Phi = f(x) = \Phi_0 = Cte$ the above equation becomes; equation (13):

$$\frac{\phi}{\phi_0} = \frac{T_s - T_f}{T_0 - T_f} = 2 \sum_{n=1}^{\infty} \lambda_n e^{-\lambda_n^2 \alpha t} \frac{\text{Sen}(\lambda_n L) \text{Cos}(\lambda_n x)}{\lambda_n L + \text{Sen}(\lambda_n L) \text{Cos}(\lambda_n L)} \quad (13)$$

The temperature $\Phi_c = T_c - T_f$ on the axis of the plate $(x = 0)$ of thickness $(2L)$ is equation (14):

$$\frac{\phi_c}{\phi_0} = \frac{T_c - T_f}{T_0 - T_f} = 2 \sum_{n=1}^{\infty} \lambda_n e^{-\lambda_n^2 \alpha t} \frac{\text{Sen}(\lambda_n L)}{\lambda_n L + \text{Sen}(\lambda_n L) \text{Cos}(\lambda_n L)} \quad (14)$$

For the second case, programming in Wolfram Mathematica 8.0, for the pipe, the procedure is similar to the previous one, but the characteristic length of the plate (L) , which varies from the surface to the center, is replaced by the (r) , which is the radius, which varies from the surface of the pipe to its inner radius, another difference, in this case, is that it is solved with the equation in cylindrical coordinates and the Bessel and Newman equations are used, due to the temperature distribution that exists in this type of geometry, in addition, in the plate, there is dependence of the Biot number and in the pipe there is not equation (15):

$$\frac{\partial^2 \phi}{\partial r^2} + \frac{1}{r} \frac{\partial \phi}{\partial r} = \frac{1}{\alpha} \frac{\partial \phi}{\partial t}, \text{ with } \phi = T - T_f \quad (15)$$

Where Φ , is the dimensionless temperature, which is a function of radius and time, T is the temperature in degrees Celsius, T_f is the final temperature. Applying the method of separation of variables, the resulting ordinary differential equations and their solutions are equation (16):

$$\frac{d^2 R}{dr^2} + \frac{1}{r} \frac{dR}{dr} = -\lambda^2 R$$

General solutions:

$$R = B_1 J_0(\lambda r) + B_2 Y_0(\lambda r) \quad (16)$$

Where R is a function, which depends only on the radius, J_0 is the zero-order first-species Bessel function, Y_0 is the zero-order second-species Bessel function (Newman function), B_1 and B_2 are constants; equation (17):

$$\frac{d\theta}{\theta} = -\lambda^2 \alpha \cdot dt, \text{ general solution: } \theta = B_3 e^{-\lambda^2 \alpha t} \quad (17)$$

Where θ is a function that depends only on time and B is a constant.

If it were a solid cylinder, then, as it cannot admit in its axis ($r = 0$), an infinite solution, because $Y_0 = -\infty$ results that B_2 has to be (0) and we obtain an equation of the form; equation (18):

$$R = B_1 J_0(\lambda r) \quad (18)$$

The general solution that provides the temperature distribution; equation (19):

$$\phi = B_3 e^{-\lambda^2 \alpha t} B_1 J_0(\lambda r) = B e^{-\lambda^2 \alpha t} J_0(\lambda r) \quad (19)$$

In which B and λ are constants that are determined by the boundary conditions.

The initial condition is:

$$t = 0; 0 \leq r \leq R; \Phi = f(r) \text{ or } \Phi_0$$

The condition for an abrupt change of temperature on the lateral surface of the infinite cylinder; equation (20):

$$\begin{aligned} \phi &= T - T_f \\ \phi_{r=R} &= 0 = B e^{-\lambda^2 \alpha t} J_0(\lambda R); J_0(\lambda R) = 0 \Rightarrow J_0(\lambda_n R) = 0 \end{aligned} \quad (20)$$

Therefore, equation (21):

$$\phi = B e^{-\lambda^2 \alpha t} J_0(\lambda r) \quad (21)$$

Which has to be fulfilled for any value of t with the conditions:

- 1) To, $t = 0; 0 \leq r \leq R; \Phi = f(r) \text{ or } \Phi_0 = T_0$
- 2) To, $t > 0; \partial\Phi/\partial r_{r=R} = -(-h_c/k)T$

Taking into account the second boundary condition and that $(\partial/\partial r)J_0(\lambda r) = -\lambda J_1(\lambda_1)$; equation (22):

$$\begin{aligned} B e^{-\lambda^2 \alpha t} [-\lambda J_1(\lambda r)]_{r=R} &= -\frac{h_c}{k} [B e^{-\lambda^2 \alpha t} J_0(\lambda r)]_{r=R} \Rightarrow \lambda R \\ &= \frac{J_0(\lambda R)}{J_1(\lambda R)} Bi; \frac{J_0(\lambda R)}{J_1(\lambda R)} = \frac{\lambda R}{Bi} = y \end{aligned} \quad (22)$$

Which is satisfied for infinite values of λ with the intersection of the curves.

Being the values of λ_n roots of the equation;

equation (23):

$$\frac{J_0(\lambda_n R)}{J_1(\lambda_n R)} = \frac{\lambda_n R}{Bi} \quad (23)$$

For the case of a pipe, with initial conditions: $t = 0; r_i \leq r \leq r_e; \Phi = f(r) \text{ or } \Phi_0$, the second constant does not become zero, as in the cylinder^[1], this is also sought, with the boundary conditions according to **Figure 2**. Its obtaining is more complex, because the constant B_2 , cannot be zero, because the center ($r = 0$), does not enter the domain and in order to obtain a solution to the problem, a constant is written as a function of the other, from the boundary conditions and thus, applying the theory of orthogonal functions, an expression for this constant is obtained. Boundary conditions for $t > 0$; equation (24):

$$r = r_e: \left(\frac{\partial\phi}{\partial r} \right)_{r=r_e} = a_1 \cdot \phi = -\frac{h_c}{k} \phi \quad r = r_i: \left(\frac{\partial\phi}{\partial r} \right)_{r=r_i} = 0 \quad (24)$$

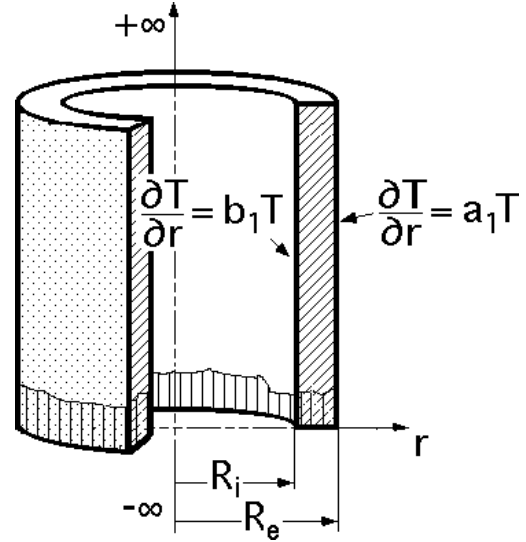

Figure 2. Interpretation of the convection boundary condition in an infinite pipe volume element.

From the boundary conditions, the transcendental equation is obtained, whose roots are the λ_n of the solution equation; equation (25):

$$\begin{aligned} \lambda_n [J_1(\lambda_n r_e) Y_1(\lambda_n r_i) - J_1(\lambda_n r_i) Y_1(\lambda_n r_e)] \\ - a_1 [J_0(\lambda_n r_e) Y_1(\lambda_n r_i) \\ - J_1(\lambda_n r_i) Y_0(\lambda_n r_e)] = 0 \end{aligned} \quad (25)$$

Where J_1 is the first-species, first-order Bessel function and Y_1 is the second-species, first-order

Bessel function.

It turns out that the general solution of the problem is a linear combination of infinite solutions, for infinite self values of λ ; equation (26):

$$\begin{aligned} \phi(r, t) &= \sum_{n=1}^{\infty} e^{-\lambda^2 \alpha t} \frac{\int_{r_i}^{r_e} r \phi_o [J_0(\lambda_n r) Y_1(\lambda_n r i) - J_1(\lambda_n r i) Y_0(\lambda_n r)] dr}{\int_{r_i}^{r_e} r [J_0(\lambda_n r) Y_1(\lambda_n r i) - J_1(\lambda_n r i) Y_0(\lambda_n r)]^2 dr} \\ &\cdot [J_0(\lambda_n r) Y_1(\lambda_n r i) - J_1(\lambda_n r i) Y_0(\lambda_n r)] \end{aligned} \quad (26)$$

The dimensional temperature is a function of time and radius, (r_i, r_e) .

$$\text{Tempi} = \Phi(r_i, t)$$

where: tempi is the a-dimensional temperature at the inner radius of the pipe.

tempe = $\Phi(r_e, t)$: A-dimensional temperature at the outer radius of the pipe.

Finally, the temperature is calculated for any time and thickness^[14]. For the temperature at the surface or outer radius (T_s); equation (27):

$$\phi(r_e, t) = \frac{T_s - T_{\infty}}{T_i - T_{\infty}} \quad (27)$$

And for the intermediate temperature or inner radius (T_o); equation (28):

$$\phi(r_i, t) = \frac{T_o - T_{\infty}}{T_i - T_{\infty}} \quad (28)$$

Assume that convection is forced because water is driven by a pump.

To give a solution to all these cases, it is necessary to know or make some calculations such as. Width: 11 = Height: 12 Length: Therefore, the area of the bathtub will be: $A_b = 11 \times 12$.

Water flow: Q ,

Calculation of water velocity: Area of water flow, $A_a = \text{Area of bath} - \text{Area of (pipe, cylinder, or plate)}$.

Pipe area = $\pi \cdot (D/2)^2$. If the water flow is known then, $Q = A_a V$ and $V = Q/A_a$.

The heat transfer coefficient (h) is calculated by calculating the Reynolds number to determine whether the regime is laminar or turbulent and using the corresponding Nusselt correlations; equation (29):

$$\text{Reynolds: } Re_D = \frac{\rho V D}{\mu} \quad (29)$$

Where ρ = Water density (kg/m^3), V = Velocity of water (m/s), D = Diameter or thickness (m); μ = Dynamic viscosity of water ($\text{N}\cdot\text{s/m}^2$). With red and the Prandt number (P_r), the Nusselt Number (N_{us}) is calculated. P_r is calculated by equation (30):

$$P_r = \frac{v}{\alpha} = \frac{\mu C_p}{k} \quad (30)$$

Where:

v = rate of momentum diffusion and α = rate of heat diffusion.

μ = Dynamic viscosity of water; C_p = Specific heat of water, k = Thermal conductivity of water $\text{W/m}\cdot\text{K}$.

This value is easily found in tables. Calculation of the Nusselt number; equation (31):

$$\overline{Nu} = C Re_D^m Pr \quad (31)$$

Applicable regime for: $0.4 < Re < 44 \times 10^5$; $P_r \geq 0.7$; where: C and m are constants taken by table according to Reynolds value. Other correlations; equation (32) and (33):

$$N_{US} = 0.3 + \frac{0.62 \cdot Re_D^{0.5} \cdot P_r^{\frac{1}{3}}}{\left(1 + \left(\frac{0.4}{P_r}\right)^{\frac{2}{3}}\right)^{0.25}} \cdot \left(1 + \frac{Re_D}{282000}\right)^{\frac{5}{8} \cdot 0.8} ; \quad (32)$$

$(Re_D \cdot P_r > 0.02)$

$$N_{US} = P_r^{0.3} \cdot (0.35 + 0.47 \cdot Re^{0.52}) \quad (33)$$

Applicable regime for: $Re > 200$ and $P_r > 0.7$.

Convective coefficient; equation (34):

$$h = Nus \frac{k}{D} \quad (34)$$

The physical properties of the material used were:

$K = 0.22 \text{ W/m} \cdot ^\circ\text{K}$ thermal conductivity. $P = 1,400 \text{ kg/m}^3$ density.

$C_p = 1,273 \text{ J/kg} \cdot ^\circ\text{k}$ specific heat.

In addition, the properties of the solid, which is cooled or heated, such as density, specific heat and thermal conductivity, must be known or calculated,

and with these elements we proceed to the programming. The flow rate of the machine used was 270 kg/h, with 143 kW of general power, 85% of this power was considered, equal to 122 kW.

The program starts, with the input of the data: Pipe diameter or width of the plate (mm), thickness for both (mm), initial material temperature (°C), cooling water temperature (°C), desired temperature (°C) for the surface, inner radius or center, machine flow rate (kg/h), heat exchanger dimensions, material and water properties, 0 type of exchange surface. With these data, it performs the cooling

time calculation, based on the flow according to machine design. Subsequently, calculate T_i and T_e according to the desired river temperature, or center and with this data the time it takes for the cooling to reach the desired temperature, depending on the case, which takes into account the thermophysical properties of the material, using the working tool (Wolfram Mathematica 8.0 software), it is compared with the desired temperature, if it is higher or lower, it is added, or subtract the desired value, until the necessary difference is reached, according to the required accuracy.

Table 1. Comparison between 90 mm diameter pipe and plate with their equivalent dimensions and properties

Thickness (mm)	5.4	4.3	3.5	2.7	2.2
Time to reach desired temperature in r_e (sec.) Piping	235	184	147	111	89
Time to reach desired temperature in r_e (sec.) Plate	215	163	128	96	75
Temperature in r_i (°C)	62	55	50	47	44
Temperature in r_e (°C)	30	30	30	30	30
Production meters of pipe 8 h according to (ρ)	1,075	1,333	1,622	2,083	2,542
Production meters of pipe 8 h according to (PF)	978	1,247	1,562	2,078	2,602
Plate meter production 8 h according to (ρ)	1,011	1,269	1,559	2,021	2,480
Plate meter production 8 h according to (PF)	1,072	1,413	1,800	2,451	3,072
Pipe volume 1 m^3	0.00116	0.001158	0.00095	0.00074	0.00061
Plate volume 1 m^3	0.00152	0.001215	0.00099	0.00076	0.00062
Plate-pipe volume difference Plate-pipe volume difference 1 m^3	0.00037	0.000057	0.00004	0.00002	0.00001

Note: (ρ) Raw material density as predominance, (PF) Thermophysical properties as a function of the cooling process.

The result of this process is a cooling time, which is related to the thermo-physical properties of the raw material introduced, with which it is carried out, a new calculation of the maximum flow rate for the machine, which is not directly related to the design flow rate, and from these results, the other results are obtained, the higher efficiency of the equipment, is that the result. According to the thermo-physical properties, is as close as possible to the productive design of the machine, calculating from this result. The report includes the production and optimal consumption indexes, at the end it makes a report of all the indicators that are requested, giving the possibility to know the values of each of the equations and variables that participate in the process. A sample of this is shown in **Table 1**, which is only a sample of a requested report. The graphs with which the intervals and coefficients are calculated for the plate and the pipe are different, since the plate is dependent on the Biot number and the pipe is not, due to different

geometries, as shown in **Graphs 1** and **2**, for a thickness of 4.3 mm. **Figure 3** shows the calculation procedure described.

3. Results and discussions

With the application of Wolfram Mathematica 8.0 as a working tool for the solution of heat transfer problems by the exact solution method, the following results, among others, can be obtained.

Develop very fast calculations in real time, of each of the parameters necessary to obtain the consumption and production index for each product.

The possibility of taking parameters, such as the same temperature difference at the extruder outlet and at the bath inlet, equal thicknesses, cooling distances, temperature at the inner and outer radius, as well as the thermo-physical properties of the material, and demonstrate how the cooling times, productions, consumption rates and volumes of the geometries under study vary.

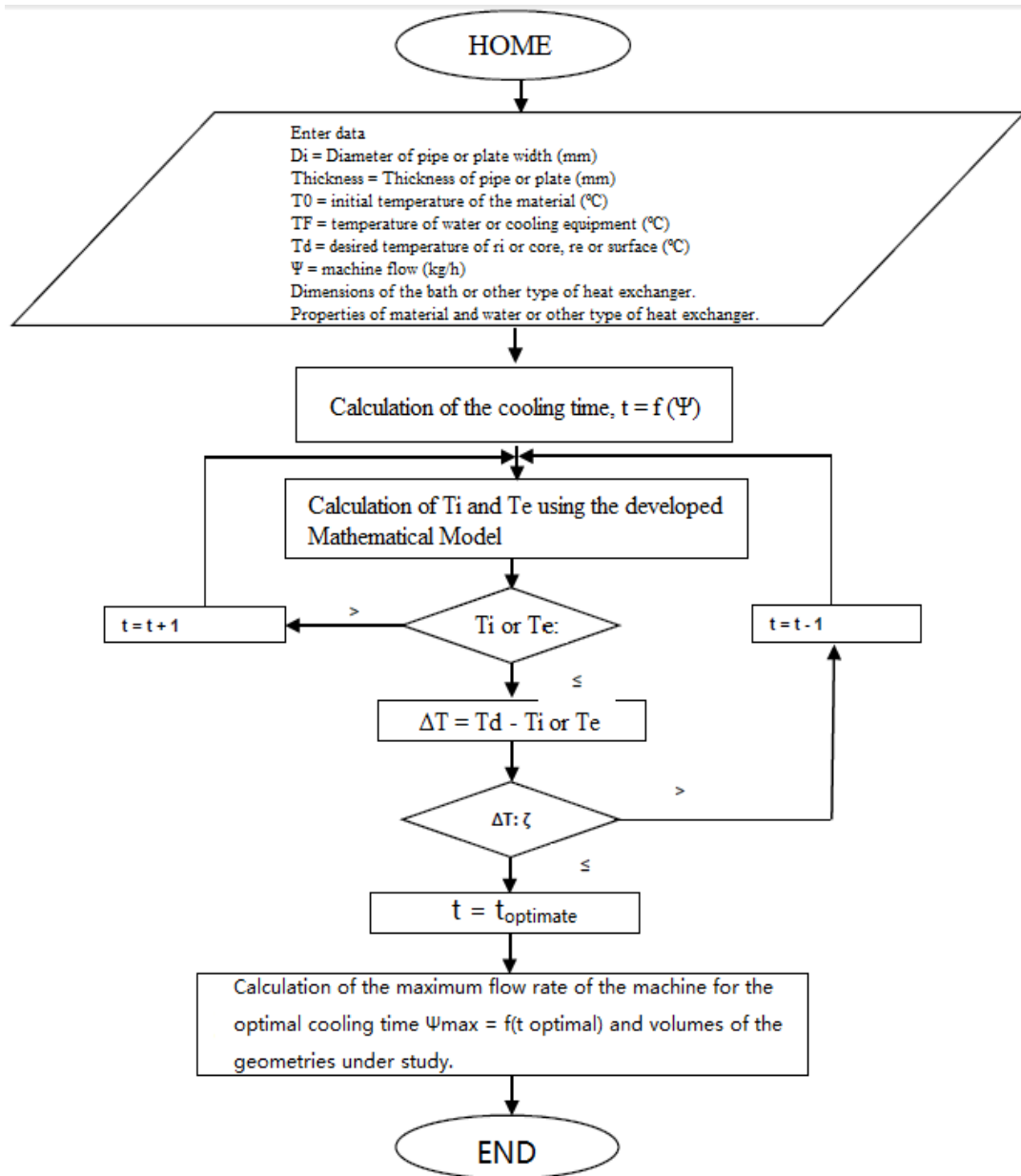
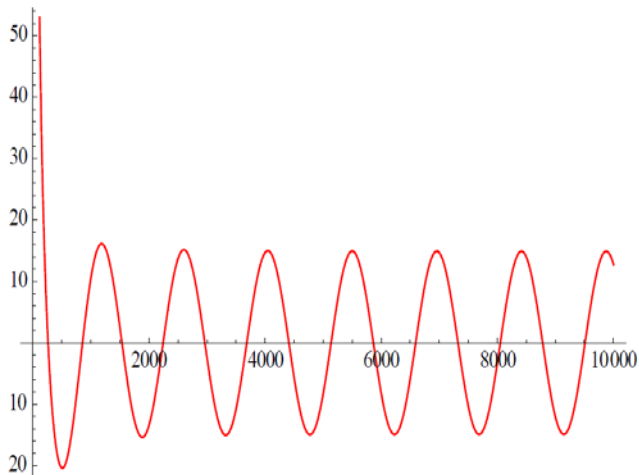
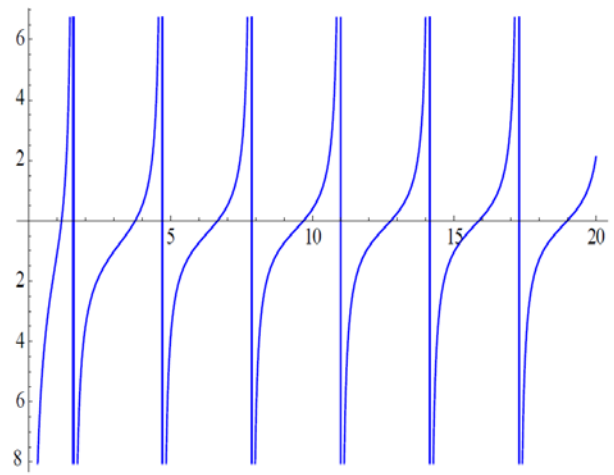

Figure 3. Flow chart of the described procedure.



Graph 1. infinite solutions for infinite eigenvalues λ_n , for pipeline.



Graph 2. Infinite solutions for infinite eigenvalues λ_n , for plate.

Table 1 shows a report of parameters obtained with the application of the tool, to which others can be added. The level of precision in real time, which is wanted to be obtained as it is from $(n = 1$ to ∞) will be fixed according to the need of the process to be executed, (productive or investigative), facility that exists for using a programming of this type.

Another example of the benefits of this application can be seen when comparing, based on its accuracy, how the volumes and cooling time decrease as the thickness decreases, tending to zero, demonstrating this condition, that truly, the thinner the thickness, the closer the values between both geometries, however, it shows the inappropriateness of using, for the solution to problems of pipes with thin thicknesses, the treatment as if it were a plate, since the rest of the indicators to be measured do not present the same situation.

With the tool, it was possible to define the two main parameters to be taken into account to achieve productive and energetic efficiency of this process. The density, with direct correspondence with the flow of the equipment and the density achieved with the thermo-physical properties of the material, depending on the cooling process, which provides one more parameter to be taken into account for any energy and production analysis.

4. Conclusions

With the use of this work tool (Wolfram Mathematica 8.0), it was demonstrated that in order to develop any analysis of the productive process and define an energetic improvement in the plastic pipe extrusion machines, it is necessary to take into account two essential elements. For the productive flow, as the main basis, the density of the raw material and from the energetic point of view, the conjugation of the thermo physical properties present in the same, since both act differently in the process.

Another example of the benefits of this application can be seen when comparing, based on its accuracy, how the volumes and cooling time decrease as the thickness decreases, tending to zero, demonstrating this condition, which is truly true,

the thinner the thickness, the closer the values between both geometries are, however, it is shown that it is not convenient to use, for the solution to problems of pipes with thin thicknesses, the treatment as if it were a plate, since the rest of the indicators to be measured do not present the same situation.

It was also demonstrated that the volumes of the plate and the pipe are reduced and tend to zero as their thicknesses decrease, but referred to the production increases in the pipe with respect to the flow of the machine, and according to the characteristics of the raw material, the production is lower than that of the plate, with these characteristics the consumption indexes behave in the same way.

Conflict of interest

The authors declared no conflict of interest.

References

1. González de Brito F. Condición de Contorno de convección en salidos infinitos (Spanish) [Boundary condition of convection in infinite outflows]. 8th ed. In: Concepción Hernández M (editor). Pedro Fernández Díez, España: Ingeniería Térmica, Universidad de Cantabria; 2003.
2. Mackowski DW. Transient and one dimensional conduction. In: Conduction heat transfer notes for MECH 7210. Auburn: Mechanical Engineering Department, Auburn University; 2011. p. 80–82.
3. Abascal R. Ecuaciones diferenciales de orden superior. Parte 5. Funciones de Bessel (Spanish) [Higher order differential equations. Part 5. Bessel functions]. Argentina: Facultad Regional Avellaneda, Buenos Aires; 2006. p. 1–60.
4. Romero-Ramírez Y. High density polyethylene piping manufacture for water transfer applications in the Holplast facility, Holguin. *Ciencia & Futuro* 2014; 4(2): 12–42.
5. Suéscum J, Correa C, Rigail-Cedeño A. Mejora de la eficiencia de una extrusora de doble tornillo utilizada en la fabricación de tuberías de PVC (Spanish) [Improving the efficiency of a twin-screw extruder used in PVC pipe manufacturing]. *Revista Tecnológica-ESPOL* 2007; 20(1): 25–30.
6. Osswald TA, Aquite W, Ramírez D, *et al.* Retos en la Industria de procesamiento de plásticos y compuestos (Spanish) [Challenges in the plastics and composites processing industry]. *Dyna* 2012; 79(175): 20–28.
7. Vargas-Isaza CA, Posada-Correa JC, Jaramillo-Zapata LY, *et al.* Energy consumption in plastic

- industry-review of studies developed. *Revista CEA* 2015; 1(1): 93–107.
8. Jiménez Ramos A, Borroto Nordelo A, Montesino Pérez M, *et al.* Improve of the energy efficiency in the processes of plastic pipe extrusion. *Ingeniería energética* 2015; 36(2): 220–229.
 9. Holman JP. *Transferencia de calor* (Spanish) [Heat transfer]. 8th ed. São Paulo: MacGraw-Hill Companies, inc.; 2013. p. 117–130, 175–184.
 10. López E, Hernández JB, Solorio G, *et al.* Mathematical model of heat transfer to predict distribution of hardness through the Jominy bar. *Revista de Metalurgia* 2013; 49(2): 111–121.
 11. Robert K, Saibel R, Ángel D. Formulation of a mathematical model to optimize the time of production in a plant extrusoras of pipes. *Universidad, Ciencia y Tecnología* 2012; 16(62): 33–41.